

LIGHTHOUSE

2024 CATALOGUE



Contents

LIGHTHOUSE & YOU

- 2023 New Products

HEATING



POLYTROPIC p.10

FEATURES p.14

SIZING CHART p.17

DOMESTIC HEAT PUMPS

- Neo Inverter p.18

- Master Inverter p.20

- Ottimo p.24

- Care 290 p.26

COMMERCIAL HEAT PUMPS

- RAK Inverter p.30



SPA AND CHILLER HEAT PUMPS

- Spa Inverter p.34

- Stepio p.36

- Cryo Inverter p.38

POLYSOLAR p.40

- Polysolar p.40

ELECTRIC HEATERS

- Nano Spa p.44

- Nano Splasher p.45

- Evolution 2 p.46



HEAT EXCHANGERS

- G2 Multi Tubular p.47

HEATING CONTROLLERS

- Pool Smart p.48

- Heat Smart p.48

- Analogue Thermostat p.48



FILTRATION

INTRODUCTION p.49

PUMPS p.51

- HF Alphaflo p.52

- HF Alphaflo VS p.54

- Hydrostar Mk 4 p.56

- Hydrostar Plus P.58

FILTERS p.60

- Micron Side Mounted p.62

- Micron Top Mounted p.64

- Exotuf Top Mounted p.66

- SMD Commercial p.68

- SMD Deep Bed p.69

Commercial

- Multi Cyclone p.70

MEDIA p.71

- Bayrol AFM p.71

- Bayrol Glass and Sand p.72

- Pump and Filter p.73

Combinations

LIGHTS p.59

- Mini Brio 2 p.74

- MID Brio p.76

- Brio WiL Controller p.78

WATER TREATMENT

BAYROL p.79

POOL CHEMICALS

- Balancers p.82

- Disinfection - Chlorine p.84

- Disinfection - Alternative p.86

- Disinfection - Shock p.87

- Algae Prevention p.88

- Flocculation p.89

- Complementary Products p.90

- My Pool Expert APP p.91

SPA CHEMICALS

- SpaTime p.92

WATER ANALYSIS

- Testers p.93

MAINTENANCE EQUIPMENT

- Maintenance Equipment p.94



DOSING

SALT CHLORINATORS p.98

- BAYROL Automatic Salt p.99
- BAYROL Smart&Easy p.100
- Mini Salt p.102
- Just Salt p.103

Pool

UV SYSTEMS p.104

- Mini UV p.104
- Just Salt UV p.105
- H.R. UV-C p.106
- Quantum p.107

ELECHO



PH AND CHLORINE DOSING - DOMESTIC p.108

- BAYROL Automatic pH p.108
- BAYROL Automatic Cl/pH p.109



BAYROL TECHNIK p.110

- Compact Controller p.111
- Analyt Controller p.112
- Pool Manager p.114
- Pool Relax p.115
- Flockmatic p.116
- Dosing Pumps p.117
- Dosing Accessories p.118



POOL CLEANING

AUTOMATIC CLEANERS p.119

ELECTRIC CLEANERS p.120

COMPARISON TABLE p.122

DOMESTIC CLEANERS

COSMY

- Cosmy 150 p.124
- Cosmy 250 p.125

P-SERIES

- P450 p.126
- P500 LED p.127
- P600 LED p.128

COMMERCIAL CLEANERS p.129

- AQUARIUS p.130
- MAGNUM JUNIOR p.130
- MAGNUM p.130
- ULTRAMAX JUNIOR p.130
- ULTRAMAX p.130

BATTERY CLEANERS

- PK Swift p.132
- PK X-Flow p.133

POOL COVERS



HF POOL COVERS p.135

- Tidal In-Pool Covers p.136
- HF Slats p.138
- The Wave p.140



COVERSEAL p.143

- Manual System p.146
- Semi-Automatic System p.147
- Automatic System p.148



VELOCITY SWIM JET

INTRODUCTION p.151

- Velocity p.153
- Velocity Swim App p.155



HF PANEL POOLS

INTRODUCTION p.158

- In-Ground Pools p.162
- Customisation p.164
- Above Ground and School Pools p.165
- Internal Steps p.169
- Sports Pools p.171

ROUND AND WOODEN POOLS



AQUATECHNICS ROUND POOLS p.177

- Introduction p.177
- Round Pools p.180



INTRODUCTION p.181

- Pistoche p.182
- Weva p.183
- Urban p.185

WELCOME

Welcome to the 2024 Lighthouse Pools catalogue, packed full of exciting new and existing products.

After a challenging year for the industry in 2023 thanks to the inclement weather and precarious economy, we are hopeful 2024 will see a change in fortune for us all. At Lighthouse, our doors and ears are always open to new ideas and fresh ways of thinking and working. It's this dynamism that drives us and enables us to bring you some of the smartest and most up to date equipment on the market today.

To extend our in-house brand HeatForm, we are pleased to launch a full range of slatted cover systems designed and manufactured in our factory based in Plymouth, Devon (see page 135).

Whilst the raw extruded slats and drive motors are sourced from one of Europe's leading manufacturers, the bespoke processing and finishing will be undertaken by the HeatForm team resulting in improved flexibility and lead times. We are offering a complete range of in-pool installation systems plus our new and attractive above ground system - The Wave, which features both electric and solar options with integrated LED lighting.

Earlier this year, the world renowned dosing and water treatment manufacturer Bayrol chose Lighthouse as their sole UK distributor and our technical team has been impressed with both the quality and support around the full range of products. Similarly, the Polytropic range of heat pumps are already proving popular with the trade due to their unique remote access system which provides us with the ability to access and monitor every single unit sold in the field. This gives valuable peace of mind and a high level of customer service in-line with our company goals.

As ever, thank you for all your continued custom and support and we look forward to working together in 2024.



Daniel Phillips
Managing Director

Technical Training Centre - Witney, Oxfordshire













To keep up with the interest in all our new products we have spent quite a bit of time this year giving our training centre based in Witney a big overhaul and it is looking better than ever. There are a number of open product specific training sessions available to book throughout spring as well as the opportunity to book bespoke sessions for your engineers. We pride ourselves on our in-depth product knowledge and maintain close links with all our manufacturers to enable us to deliver training which is targeted, useful and customer focused.

The training centre is set up and fitted out with two fully functioning HeatForm pools, both equipped with Velocity swim jets which are available for customer trials. For more information about booking in, get in touch with the team.

> LIGHTHOUSE SERVICE COMMITMENTS

It is easy to talk about delivering a good service to your customers but here at Lighthouse, we take real pride in our customer relations. For over fifteen years, Lighthouse has striven to make client satisfaction a top priority. We value listening, recognise your own expertise in the field and aim to deliver a reliable, efficient service in return.

WHO ARE WE?

			
Daniel Phillips Managing Director	John Whiteside Business Development Manager UK	Andy Butcher Accounts	Greg Wallis Quality and Production Manager
			
Phil Bean Sales Co-ordinator	Dexter Coultas Sales Co-ordinator	Miranda Rogers- Clarkson Sales Administrator	Sadie West Purchasing Administrator
			
Duncan Hedges Logistics & Shipping	Chris Skinner Logistics & Shipping		

CONTACT US:

 **Tel:** 01752 253525  **E-mail:** sales@lighthousepools.co.uk

2024 NEW PRODUCTS

Polytropic Heat Pumps

Polytropic have been designing and manufacturing swimming pool heat pumps in Europe for 17 years. They are now the number one seller of swimming pool heat pumps in Europe and have a reputation for both quality and reliability.

As dedicated pool heat pump manufacturers, Polytropic have built up a reputation for being the best for performance and reliability. Now partnered with Lighthouse, the full range of Polytropic heat pumps are available exclusively to the UK trade.

All Polytropic heat pumps come with a full 5 year parts and labour warranty, which is supported by the active remote monitoring system, connected to the UK's 4G mobile phone network. This allows our in-house technicians based in Plymouth to remotely access the machines, reporting back to you on the status of the heat pump. This system ensures all Polytropic heat pumps are set up and operating to give the optimum performance.



2024 NEW PRODUCTS

Domestic and Commercial Filtration



To compliment our exclusive range of heating and water treatment systems, Lighthouse have partnered with world leaders in filtration, Waterco. As stockists and distributors we supply the ever popular Micron filters, Multi-cyclone pre-filters and the NEW HeatForm Alphaflo pumps



BAYROL AFM® Media



What is BAYROL AFM® ?

AFM® is the best performing filter media on the market with a certified 1 micron filtration rate.

AFM® is 100% bio-resistant: Prevents bacterial growth in the filter bed.

AFM® is a sustainable product made of recycled glass.
Your benefits at a glance:

- Crystal clear water.
- Lower chlorine consumption.
- No chlorine smell and up to 50% less THMs.
- The risk of infections by bacteria and parasites such as Legionella, Pseudomonas and Cryptosporidium is reduced to an absolute minimum.
- Same performance for many years. AFM® outlasts all other filter media.

2024 NEW PRODUCTS

BAYROL - Commercial Dosing and Water Treatment



BAYROL has been a true expert in the field of water treatment for swimming pools and spas for over 65 years.

Over the decades, sustainable developments as well as high innovation combined with operational excellence, have resulted in a product range that meets all the requirements for optimum water care, therefore guaranteeing a high rate of customer satisfaction.

MAKING COMPLEX THINGS SIMPLE

Since the 1950s, we have been passionate about developing water care products for pools and spas that are efficient and easy to use.

This has resulted in numerous innovations and patents that are well known among pool owners, for instance active oxygen water care in granular form in pre-dosed sachets, and various multifunctional products like the double layer tablet.

For a better understanding and to support pool owners in the best way possible, we have divided water treatment into four essential steps: 1. Water balance 2. Disinfection 3. Algae prevention and 4. Flocculation.

For hygienic reasons, the pool water must always be sanitised. Disinfection is therefore an essential step in water care to which we draw particularly high attention.



Our goal is to provide you with pool water care solutions that are as simple, safe and efficient as possible. However, this can only be achieved through the quality of our products.

Only a few manufacturers in Europe maintain their own research laboratory as we do, where we continuously improve and enhance our product range.

We thoroughly select all raw materials and carefully test our products throughout the process - from production to market launch. With this high level of standards, we have been accompanying you as the experts for water treatment in pools and spas for over 65 years.

2024 NEW PRODUCTS



Over the last several years, Lighthouse has been expanding its portfolio of pool covers to support the UK trade, now offering a carefully selected range of automatic covers to suit a variety of needs and end-user budgets.

HeatForm: The Wave

Designed to be as attractive as it is playful and robust as it is reliable, The Wave is British by design and manufacture - coming straight out of the HeatForm production facility in Plymouth, Devon.

The Wave was principally created to offer an entry level slatted cover system for customers looking for a flexible retrofit option which also incorporated an element of fun! The end housings have integrated LED RGB strip lights, with colour options to add some entertainment to a midnight swim, or to add some extra security to any early morning exercise sessions.

The roller system fixes quickly and easily onto the pool surround coping and each cover is custom made ensuring the best possible fit. Available in a range of coloured Polycarbonate, PVC or solar slats it is particularly suited to pools with skimmers or infinity pools.

The Wave can either be driven from a transformer or by battery which is kept charged from a solar panel mounted on the side of the housing and opened and closed with a remote fob or key switch .

If required, The Wave roller system can be bought separately for use with bubble or foam covers.

HeatForm Tidal In-Pool slatted covers

HeatForm Tidal Pool covers are a range of in-ground submerged covers which are elegantly designed and engineered to last; intended as a little extra luxury in the pool design.

Available in five installation configurations including a shallow water beach entry system with steps - unique to HeatForm - which is our most popular model – enabling somewhere to sit and dangle your feet on hot summers days whilst keeping the cover safely tucked away. Other options include the deep water bench, cave system, a simple submerged roller option and the discreet letterbox pit system hidden behind the pool walls.

The HeatForm Tidal Pool cover offers high quality coloured PVC or Polycarbonate and solar slat options and is controlled by remote or key switch for ease of use.

The stainless-steel fittings and brackets are designed and built, by HeatForm, in the UK, ensuring fast lead times and quality products which are guaranteed to last.



2024 NEW PRODUCTS

Aqua Technics Round Pools

**AQUA
TECHNICS
POOLS**



For nearly five decades, Aqua Technics Pools has crafted exceptional one-piece composite pools, earning many accolades along the way. Their cutting-edge swimming pools, produced in a state-of-the-art facility near Perth, Western Australia, epitomise technological advancement and superior craftsmanship. Situated in Australia, renowned for its abundant home swimming pools, their products cater to the most discerning global consumers, tailored for durability in the world's harshest climates.

As a family-owned enterprise for over 47 years, their commitment remains unwavering. Their pools, designed for longevity, have reached all corners of the globe. Aqua Technics' primary aim revolves around ensuring families delight in their pool experience, creating enduring memories that span lifetimes.

AQUA TECHNICS POOLS CRAFT THE FINEST ONE-PIECE COMPOSITE POOLS AVAILABLE GLOBALLY. ENGINEERED FOR ENHANCED AESTHETICS AND ENDURING DURABILITY.

Available exclusively from Lighthouse the Aqua Technics round pools are the perfect solution for the smaller British garden. Delivered pre-plumbed, find out more about the round pools on page 177.



Pool Heating

POLYTROPIC FEATURES	p.10	ELECTRIC HEATERS	
SIZING CHART	p.14	• Nano Spa	p.44
DOMESTIC HEAT PUMPS	p.17	• Nano Splasher	p.45
• Neo Inverter	p.18	• Evolution 2	p.46
• Master Inverter	p.20	HEAT EXCHANGERS	
• Ottimo	p.24	• G2 Multi Tubular	p.47
• Care 290	p.26	HEATING CONTROLLERS	
COMMERCIAL HEAT PUMPS		• Pool Smart	p.48
• RAK Inverter	p.30	• Heat Smart	p.48
SPA AND CHILLER HEAT PUMPS		• Analogue Thermostat	p.48
• Spa Inverter	p.34		
• Stepio	p.36		
• Cryo Inverter	p.38		
POLYSOLAR	p.40		
• Polysolar	p.40		



Energy efficiency, classification of swimming pool equipment according to its energy performance, lifespan of equipment and increased reliability...

At a time when ecological issues are at the centre of everyone's concerns, the energy consumption of swimming pools is under the spotlight.

Beyond the regulations and reliable, economical and connected equipment, many efforts will be required of pool professionals. It is up to us, designers and manufacturers, **to provide the solutions and products now to meet the expectations of pool owners for years to come.**

The Polytropic range is wide-ranging, innovative

and enables you to **respond accurately to the specific needs of the pool market and to the new energy challenges that characterise it!**

For this new season, which promises to be full of challenges, POLYTROPIC will accompany you with **complete ranges of reliable pool heat pumps designed in a sustainable global approach.**

More than ever, we are putting all our **expertise** and the efficient support of our **Customer Service** at your disposal.

REDUCING THE
ENVIROMENTAL IMPACT
OF SWIMMING POOLS,
WHETHER PUBLIC OR PRIVATE
THROUGH A NEW APPROACH,
NEW TECHNOLOGIES AND
NEW METHODS





Sustainable solutions

Energy efficiency is no longer enough, it is the overall impact of the swimming pool that matters. As a designer-manufacturer specialised in heat pumps, we are committed to meeting and surpassing regulatory requirements!

Being a pioneer in Inverter technology, we have developed an entire range of swimming pool heat pumps using low-impact R32 refrigerant gas. Now its up to us to go further using R290 (Propane) we have developed a range specific for residential swimming pool heating.

R290, NATURAL AND NEUTRAL FOR THE ENVIRONMENT

R290 is an excellent alternative to HFC Refrigerant gas due to its low environmental impact and excellent thermodynamic properties. Furthermore, it has no restrictions that limit its use in industrial environments.

The advantages of R290 :

- Natural
- Reliable
- Low global warming impact
- No impact on the Ozone layer
- High energy efficiency (COP of 6 @15° Air)
- Low maintenance not subject to leak tests

For comparative purposes:

R290	G.W.P* = 3
R32	G.W.P* = 675

*GWP : Global Warming Potential of a gas

Reducing the product's impact throughout its life through **reliability, repairability, low energy consumption and a recycling program** but also in the way we work. The essence of our business and expertise is in practicing and proposing innovative solutions.

We therefore **propose a hybrid approach in coupling a photovoltaic panel kit to your swimming pool Heat Pump.**

As a major player in the market, we have

always been diligent in doing our part and are conscious of our environmental impact.

In order to formalise our approach, this year we have engaged and are involved in :

✓ The calculation of our **Carbon footprint**

✓ The **Positive Workplace RSE label**

The objective is **to take stock and establish a road map to further evolve our practices.**

Since 2020, we have also committed ourselves to 'Planet urgence' and take

part in its program of **environmental development through reforestation projects of our ecosystems, local economic development and the mobilisation against climate change.**

More information on www.planete-urgence.org

Environmental norms and energy classification

At the time of writing of this catalogue, **The European standard on environmental performance efficiency of domestic swimming pools NF EN 17645** was just published: important news for our industry !

The Federation of swimming pool professionals (FPP) have been working in partnership since 2018 with AFNOR and **the European committee on the implementation and acceleration of this new standard of more environmentally friendly swimming pools.**

The standard provides an environmental assessment of the use of domestic swimming pools installed permanently outdoors and taking into account the entire installation : Water, filtration, lighting, building material, heating etc...

The swimming pool professional submits a document

constituting the global performance of the entire swimming pool installation to the end client showing an estimation of annual cost to operate.

This document then allows the end user to make an educated and environmentally concious decision.

As a major player in the swimming pool market and a specialist in swimming pool heating, Polytropic is actively engaged with the FPP in **piloting the ' commitee in swimming pool heating '** and has been involved in contributing the norms in swimming pool heating.

The energy class compares the SCOP (seasonal coeficiency of performance) of the swimming pool Heat Pumps chosen under the same working conditions.

AS A DESIGNER MANUFACTURER, IT IS HAS BEEN IMPORTANT TO US AND OUR ETHOS TO DEVELOP EQUIPMENT WITH A LOW ENVIRONMENTAL IMPACT WHICH IS WHY WE ARE PROUD TO LAUNCH A LOW ENERGY, FULL INVERTER SWIMMING POOL HEAT PUMP!

Voluntarily, the energy class is affixed to all equipment in order to display efficiency. Together an energy score is calculated and is represented by a letter representing the overall swimming pool - A for the best environmental impact grade and F for the least virtuous.

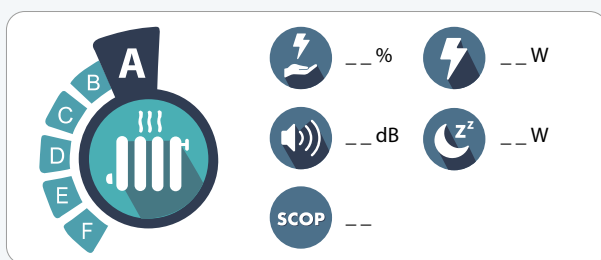

Labeling of Heating equipment

- The energy reduction coefficient of a heating device (Obligatory)**
- The noise level of the device is guaranteed (Optional)**
- The SCOP (seasonal coefficient of performance) and its corresponding environmental performance.**
- Absorbed power when on (in Watts)**
- Absorbed power when in standby mode (in Watts)**

Our commitment

As a **designer/manufacturor** specializing in swimming pool heating **since 2003**, we are proud to offer you **a complete range of reliable pool heat pumps** designed with **a sustainable global approach.**

Our entire team, **from the product design stage to the after sales service**, is involved and committed to **customer satisfaction:**



RELIABLE PRODUCTS

Beyond the respect for safety standards, we systematically check, through strict methodological test procedures, the performances and the robustness of our products.



ADAPTED SOLUTIONS

Our capacity to listen and to understand the specific needs of our partners, to respond efficiently and to provide innovative solutions at the right price allows us to create long term partnerships.



LONG TERM PARTNERSHIP

We pride ourselves in providing quality assistance to our professional customers and end users. Our technical team is at your service to reply to all queries in short notice.

Our certifications



FPP

Polytropic is an active member of the French Pool Federation (Fédération des Professionnels de la Piscine - FPP) and an Environment Committee and heating task force leader in management and production quality.



ROHS CERTIFICATION

All the electric and electronic components mounted on the heat pumps produced and distributed by Polytropic are free from dangerous substances.



ISO STANDARDS

All the Polytropic production sites are compliant with the international standard ISO 9001 :2008



CTTM

Most of the Polytropic heat pumps sound levels are measured and qualified by the independent French laboratory of the Centre de Transfert de Technologie du Mans (CTTM) thanks to a recognized expertise in industrial acoustics field.



TUV PARTNERSHIP

All the Heat Pumps are certified by an independent TÜV laboratory in compliance with the European norms for the following standards:

- Noise level: ISO/EN 354 standard,
- Heating capacity: ISO/EN 5151 standard,
- CE EMC and LVD standard



F-GAS REGULATION

All the heat pumps made by Polytropic are charged with R290, R32 and R410a gases and are in line with the current F-GAS regulation



ECO-PARTICIPATION

Polytropic pays the eco-contribution to ECOSYSTEMES for the recycling of heat pumps



PLANETE URGENCE

Polytropic contributes to the Planète Urgence Environment & Development Program combining reforestation, economic development and environmental protection.



CITEO

Polytropic is a member of the CITEO organisation, which works on efficient solutions for the recycling of packaging.



Our design office

COMMERCIAL POOLS

In order to assist you in selecting the correct solution for their heating project.

LIGHTHOUSE's technical design office provides support by proposing a suitable solution for each pool! You will be guaranteed:

- > A team of dedicated and professional technicians that will assist and advise in selecting the ideal product for your swimming pool
- > A choice of relevant equipment at the best price
- > A selection of essential accessories to be able to complete the installation
- > Optimal operation of the facility

Making sure that your offer meets the specifications of the project and the customer's request.



A HEAT PUMP FOR EVERY TYPE OF POOL



RESIDENTIAL
POOLS



OTTIMO



MASTER-INVERTER



CARE290



RAK INVERTER



MASTER-INVERTER XL



COMMERCIAL
POOLS



SMALL AND
ABOVE GROUND POOLS

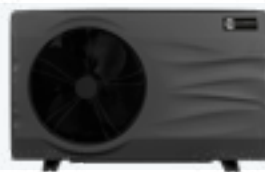

NEO INVERTER

CRYO
INVERTER



SPA
INVERTER



STEPIO



SPA &
WELLNESS

FEATURES

Line	TFT color touch screen	LCD touch screen	Large LCD screen	PolySmart Control	PolyConnect Inside	PolySolar Energy system compatible
NEO-INVERTER		●		●	●	●
MASTER-INVERTER	●			●	●	●
OTTIMO	●			●	●	●
CARE290	●			●	●	●
RAK INVERTER	●			●	●	●
CRYO INVERTER			●	●	●	●
SPA INVERTER			●	●	●	●
STPIO			●	●	●	●



Colour TFT touch screen

A LARGE HIGHLY RESPONSIVE COLOUR TOUCH SCREEN

- High capacity TFT touch screen with a 480x480 resolution IPS panel
- Protected by a layer of thermal toughened glass to ensure maximum resistance
- Large size for good readability: L 72 x H 68 mm, 4" diagonal (over 10.5 cm)
- The mounting box with its transparent protective door protects the display from climatic conditions, dust and scratches. The screen and internal components are protected from damage.

A MULTILINGUAL CONTROL INTERFACE

Intuitive navigation for ease of operation, settings and all the diagnostic information can be simultaneously viewed.



Access the 3 intuitive operating modes in a single gesture!



Alarm messages, diagnostics and problem resolutions, hotline contact



Access to the last 50 log-book events

LCD touch screen

A BRIGHT INTUITIVE USER INTERFACE

- Large size for good readability
- Intuitive navigation and settings
- User friendly



PolySmart Control: a sizeable asset

EXCLUSIVE REGULATION AND ENERGY SAVINGS

- **Optimization of the power required for maintaining the temperature of the pool** by cross-referencing air temperature with water temperature data
- **Anticipation of the pool's energy needs** thanks to an advanced double-entry regulation.
- **An overall higher COP** during the season and **lower noise levels.**
- Inverter compressor with oversized exchangers = higher COP.
- Brushless variable speed fan = lower noise levels
- Combination of the Inverter compressor and the brushless fan motor = **automatic regulation of the power when the pool does not require full power.**

3 OPERATING MODES



The heat pump will raise its heating capacity to near full capacity in order to heat the pool water rapidly.



The output and the noise levels are automatically optimized by taking into account both the air and water temperatures.



The maximum power output is limited in order to prioritize noise over heating power.



Warranties

All our swimming pool Heat Pumps have a minimum 3-year warranty to cover spare parts, labour and field servicing.

Our Premium ranges benefit from a 5-year warranty. These include Master Inverter, Ottimo, Care 290 and RAK.





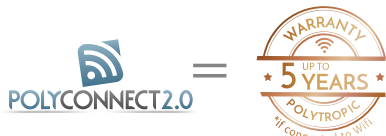

Easily **connect** the heat pump by scanning the QR code, **control** via the free app and **get secure remote monitoring for preventive maintenance and remote diagnosis by Polytropic technicians.**



HEAT PUMP SIZING

A Solution For All Pools

HEAT PUMP SIZING MAY TO SEPTEMBER Based upon 14hrs filtration, 28°C, pool covered for 20hrs average depth 1.2 - 1.8m	Neo Inverter	Master Inverter	Ottimo	Care 290
				
6 x 3 m (20 x 10 ft)	05	S	S	S
8 x 4 m (26 x 12 ft)	10	S+	S+	S+
9 x 4.5 m (30 x 14 ft)	12	M	M	M
10 x 5 m (32 x 16 ft)	15	XM	XM	XM
12 x 6 m (40 x 20 ft) Based upon 16hrs Filtration	N/A	XM	XM	XM

HEAT PUMP SIZING APRIL TO OCTOBER Based upon 14hrs filtration, 28°C, pool covered for 20hrs average depth 1.2 - 1.8m	Neo Inverter	Master Inverter	Ottimo	Care 290
				
6 x 3 m (20 x 10 ft)	08	S	S	S
8 x 4 m (26 x 12 ft)	12	M	M	M
9 x 4.5 m (30 x 14 ft)	15	XM	XM	XM
10 x 5 m (32 x 16 ft)	N/A	XM	XM	XM
12 x 6 m (40 x 20 ft) Based upon 24hrs Filtration	N/A	L+	N/A	N/A



NEO INVERTER

- EXTREMELY LOW NOISE LEVEL
- INTUITIVE OPERATING MODES : BOOST, SMART & SILENCE
- HIGH-PERFORMANCE VARIABLE SPEED COMPRESSOR
- UP TO 30 TO 40 % MORE EFFICIENT COP
- OPERATES DOWN TO 0° C
- ECO-FRIENDLY R32 REFRIGERANT GAS
- ABS CASING WITH ANTI-UV PROTECTION
- MYTECH-CONNECT INCLUDED
- 3-YEAR WARRANTY - PARTS AND LABOUR

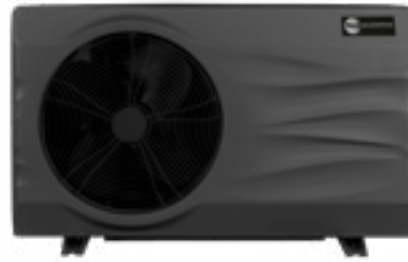

	NEO 05	NEO 08	NEO 10	NEO 12	NEO 15
PRODUCT CODE - E	IVB05-K9	IVB08-K9	IVB10-K9	IVB12-K9	IVB15-K9
PRICE GBP	£1,606	£2,214	£2,349	£2,970	£3,105

ACCESSORIES INCLUDED IN THE PACK

	
Winter cover	PVC fittings 1/2" unions and anti vibration feet

EQUIPMENT

- Horizontal venting
 - ABS casing with Anti-UV Protection
 - LCD display
 - Heating priority mode (filtration pump control)
 - Automatic defrosting
 - Automatic cooling mode (cycle inversion)
 - Titanium heat exchanger, compatible with salt water treatment
 - Full inverter technology (variable speed compressor and fan)
- 3 operating modes:
- Boost: max power for fast heat-up
 - Smart: automatic power adjustment from Ecosilence to Boost
 - Ecosilence: reduced power to further energy savings and the lowest noise level
- "2D" Full DC Twin-Rotary Inverter compressor and high accuracy variable speed fan from 20hz to 100hz

PERFORMANCE: AIR 26°C / WATER 26°C / HUMID. 80%

Model	NEO 05	NEO 08	NEO 10	NEO 12	NEO 15
Power Output (kW)	7	10.3	12.2	14.8	20.4
Power Consumed (kW)	1.1	1.7	2.2	2.9	4.1
COP average	5.4	6.2	5.6	5.1	5.2

PERFORMANCE: AIR 15°C / WATER 26°C / HUMID. 70% NF MARK

Power Output (kW)	5.5	7.3	9.5	10.5	14.8
Power Consumed (kW)	1.1	1.7	2.2	2.9	4.1
COP average	4.2	4.1	4.1	4.2	4.5

TECHNICAL SPECIFICATIONS

Average water flow (m ³ /h)	4	4	5	6	6
Hydraulic connection	PVC 1/2" union				
Electric power supply	230V / 1 / 50Hz				
Recommended Protection (A)	C10	C16	C16	C16	C20
Power cable size (not included)**	3x2.5		3x4		3x4
Acoustic power at 10 m (dB(A) mode Boost / Silent)	22 - 28	26 - 31	27 - 33	27 - 34	37 - 34

DIMENSIONS

Model	NEO 05	NEO 08	NEO 10	NEO 12	NEO 15
Weight - kg	48	52	52	57	77
Length - mm	936	936	936	1006	1006
Width - mm	323	323	323	344	344
Height - mm	570	570	570	628	711

INSTALLATION

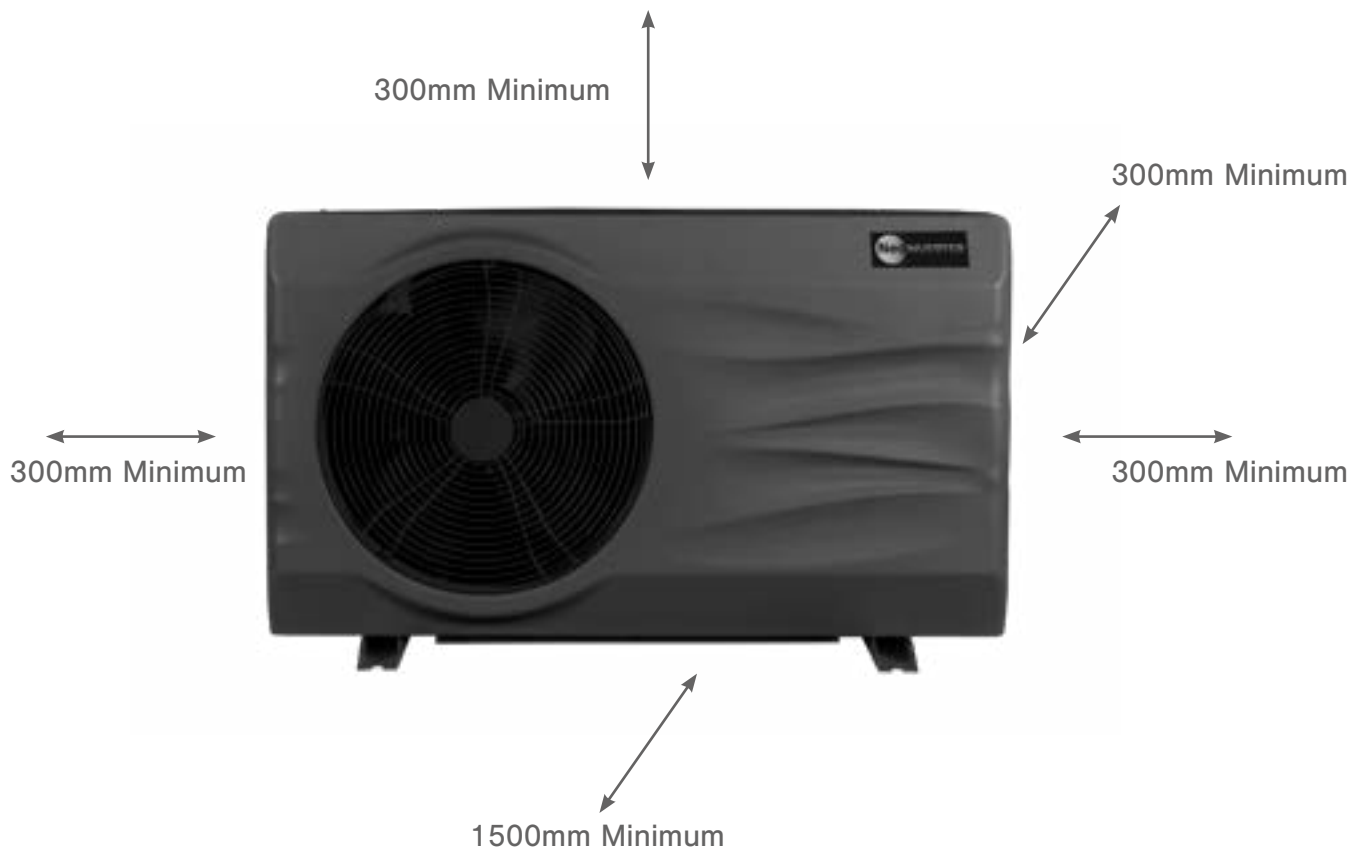



MASTER INVERTER

- EXTREMELY LOW NOISE LEVEL
- INTUITIVE OPERATING MODES : BOOST, SMART & SILENCE
- HIGH-PERFORMANCE VARIABLE SPEED COMPRESSOR
- UP TO 30 TO 40 % MORE EFFICIENT COP
- OPERATES DOWN TO -15° C
- ECO-FRIENDLY R32 REFRIGERANT GAS
- ABS CASING WITH ANTI-UV PROTECTION
- POLYCONNECT INCLUDED
- 5-YEAR WARRANTY - PARTS AND LABOUR



	XS	S	S+	M	XM	L+
PRODUCT CODE - E	IVS07-K0	IVS08-K0	IVS10-K0	IVS12-K0	IVS15-K0	IVS24-K0
PRICE GBP	£2,373	£2,882	£3,403	£4,190	£5,081	£7,397

	M 3 Phase	XM 3 Phase	L+ 3 Phase	XL 3 Phase
PRODUCT CODE - E	IVS12-K0 Tri	IVS15-K0 Tri	IVS24-K0 - Tri	IVS28-K0 Tri
PRICE GBP	£4,977	£5,959	£7,626	£9,364



SIMPLE AND INTUITIVE OPERATION

Color digital touch screen.

Three operating modes:

Heating, Cooling and Automatic.



INTELLIGENT OPERATING MODE

PolySmart Control: the heat pump autoregulates its output depending on the water and air temperature.

OPTIMAL PERFORMANCES



Optimal Twist: Titanium exchanger in a PVC housing, efficient and corrosion resistant.



2D Technology: inverter compressor, higher COP thanks to the Hz by Hz variable speed motor.



DC Brushless: variable speed fan motor ensures optimal performances.



EXCLUSIVE «LOW TEMPERATURE» SYSTEM

- Reverse-cycle defrosting,
- Preheating of the compressor housing,
- Antifreeze system for the evaporators condensation,
- Automatic piloting of the 'low temperature' system.



RECYCLED MATERIAL

Casing made from 70% recycled material and UV treated



LOW NOISE LEVELS

Noise reduction insulation on all panels and rotation speed of the compressor and fan automatically adjusted to reduce noise to the minimum.



CONNECTED SOLUTION

PolyConnect inside : wifi module and 4G card included allowing for remote control and supervision from our Technicenter **See p.11**

Technical specifications

1-PHASE MODELS	Master-Inverter XS	Master-Inverter S	Master-Inverter S+	Master-Inverter M	Master-Inverter XM	Master-Inverter L+
SCOP according to EN 17645	7,5	8,9	8,3	7,3	7,0	7,0
Classification acc. to EN 17645	A	A	A	A	A	A
Air 26°C / Water 26°C / Humidity 80%						
Energy Output BOOST mode	9,3 kW	10,6 kW	13,1 kW	16,1 kW	20,4 kW	27,8 kW
COP BOOST Mode	5,5	7,3	6,3	5,3	5,2	5,2
Energy Output SMART mode	9,3 ~ 3,5 kW	10,6 ~ 3,9 kW	13,1 ~ 4,2 kW	16,1 ~ 5,5 kW	20,4 ~ 6,5 kW	27,8 ~ 10,5 kW
COP SMART Mode	5,5 ~ 10,8	7,33 ~ 10,8	6,3 ~ 11,2	5,3 ~ 10,8	5,2 ~ 10,1	5,2 ~ 10,1
Energy Output ECO-Silence mode	3,5 kW	3,9 kW	4,2 kW	5,5 kW	6,5 kW	10,5 kW
COP ECO-Silence Mode	10,8	10,8	11,2	10,8	10,1	10,1
Air 15°C / Water 26°C / Humidity 70%**						
Energy Output BOOST mode	6,6 kW	7,8 kW	9,8 kW	11,5 kW	14,8 kW	22,9 kW
COP BOOST Mode	5,2	5,6	4,7	4,4	4,5	4,2
Energy Output SMART mode	6,6 ~ 3,2 kW	7,8 ~ 3,5 kW	9,8 ~ 3,7 kW	11,5 ~ 4,2 kW	14,8 ~ 4,9 kW	22,9 ~ 8,1 kW
COP SMART Mode	5,2 ~ 6,7	5,6 ~ 7,1	4,7 ~ 7,1	4,4 ~ 6,7	4,5 ~ 6,6	4,2 ~ 6,5
Energy Output ECO-Silence mode	3,2 kW	3,5 kW	3,7 kW	4,2 kW	4,9 kW	8,1 kW
COP ECO-Silence Mode	6,7	7,1	7,1	6,7	6,6	6,5
Air 7°C / Water 26°C / Humidity 90%						
Energy Output BOOST mode	3,6 kW	4,9 kW	7,9 kW	9,0 kW	11,7 kW	17,6 kW
COP BOOST Mode	3,7	3,6	3,8	3,8	3,8	3,7
Air -7°C / Water 26°C / Humidity 0%						
Energy Output BOOST mode	3,4 kW	4,7 kW	5,5 kW	6,8 kW	8,3 kW	12,0 kW
COP BOOST Mode	2,8	3,9	3,6	2,8	3,0	2,8
Noise level min-max (at 10m) CTTM certified acc. to EN ISO 3741 : 2010 ***	22 ~ 28 dB(a)	26 ~ 30 dB(a)	26 ~ 31 dB(a)	27 ~ 33 dB(a)	27 ~ 34 dB(a)	28 ~ 35 dB(a)
Noise level min-max (at 10m) acc. to EN ISO 3744 : 2010	21 ~ 25 dB(a)	23 ~ 26 dB(a)	23 ~ 28 dB(a)	25 ~ 30 dB(a)	25 ~ 30 dB(a)	26 ~ 32 dB(a)
Temperature working range	-15°C > 38°C					
Installation						
Hydraulic connections	1,5" / 50 mm					
Power	230V / 1~+N / 50 Hz					
Circuit breaker and cable size (for 20 m)	C 10 A (3G 2,5 mm ²)	C 16 A (3G 2,5 mm ²)	C 16 A (3G 2,5 mm ²)	C 20 A 3G 4 mm ²)	C 20 A (3G 4 mm ²)	C 32 A (3G 6 mm ²)
Power Input Max (air 28°C)	1,8 kW	2,0 kW	2,4 kW	3,4 kW	4,1 kW	6,0 kW
Minimum water flow	3 m ³ /h	3 m ³ /h	4 m ³ /h	5 m ³ /h	6 m ³ /h	10 m ³ /h
Dimensions in mm (L x W x H)	980 x 419 x 584	980 x 419 x 584	980 x 419 x 584	1080 x 479 x 707	1080 x 479 x 707	1178 x 525 x 569
Weight net (gross)	46 kg (58 kg)	48 kg (59 kg)	48 kg (59 kg)	62 kg (72 kg)	63 kg (80 kg)	94 kg (111 kg)

* May to September with cover.

** Tests run with air temperature of 15°C, water inlet temperature of 26°C and water outlet temperature of 28°C in order to define the required water flow, heating capacity and consumption. In accordance with FPP recommendations (French Pool Federation).

***The BOOST and ECO mode noise levels at 10m are certified by the independent testing laboratory of Centre de Transfert de Technologie du Mans (CTTM) according to EN ISO 3741 : 2010.

Technical specifications

3-PHASE MODELS	Master-Inverter M Tri	Master-Inverter XM Tri	Master-Inverter L+Tri	Master-Inverter XL Tri
SCOP acc. to EN 17645	7,3	7,0	7,0	9,1
Classification acc. to EN 17645	A	A	A	A
Recommended pool size*	70-85 m ³	85-105 m ³	130-160 m ³	160-190 m ³
Air 26°C / Water 26°C / Humidity 80%				
Energy Output BOOST mode	16,1 kW	20,4 kW	27,8 kW	35,6 kW
COP BOOST Mode	5,3	5,2	5,2	5,6
Energy Output SMART mode	16,1 ~ 5,5 kW	20,4 ~ 6,5 kW	27,8 ~ 10,5 kW	35,6 ~ 12,8 kW
COP SMART Mode	5,3 ~ 10,8	5,2 ~ 10,1	5,2 ~ 10,1	5,6 ~ 13
Energy Output ECO-Silence mode	5,5 kW	6,5 kW	10,5 kW	12,8 kW
COP ECO-Silence Mode	10,8	10,1	10,1	13,0
Air 15°C / Water 26°C / Humidity 70 R**				
Energy Output BOOST mode	11,5 kW	14,8 kW	22,9 kW	28,0 kW
COP BOOST Mode	4,4	4,5	4,2	4,7
Energy Output SMART mode	11,5 ~ 4,2 kW	14,8 ~ 4,9 kW	22,9 ~ 8,1 kW	28 ~ 9,6 kW
COP SMART Mode	4,4 ~ 6,7	4,5 ~ 6,6	4,2 ~ 6,5	4,7 ~ 6,7
Energy Output ECO-Silence mode	4,2 kW	4,9 kW	8,1 kW	9,6 kW
COP ECO-Silence Mode	6,7	6,6	6,5	6,7
Air 7°C / Water 26°C / Humidity 90%				
Energy Output BOOST mode	9,0 kW	11,7 kW	17,6 kW	23,3 kW
COP BOOST Mode	3,8	3,8	3,69	4,2
Air -7°C / Water 26°C / Humidity 0%				
Energy Output BOOST mode	5,8 kW	8,3 kW	12,0 kW	14,7 kW
COP BOOST Mode	2,8	3	2,81	2,9
Noise level min-max (at 10m) CTTM certified acc. to EN ISO 3741 : 2010 ***	27 ~ 33 dB(a)	27 ~ 33 dB(a)	28 ~ 34 dB(a)	35 ~ 41 dB(a)
Noise level min-max (at 10m) acc. to EN ISO 3744 : 2010	25 ~ 30 dB(a)	25 ~ 30 dB(a)	26 ~ 32 dB(a)	32 ~ 38 dB(a)
Temperature working range	-15°C -> 38°C			
Installation				
Hydraulic connections	1,5" / 50 mm			
Power	400 V / 3~+N / 50 Hz			
Circuit breaker and cable size (for 20 m)	3P +N C16 (5G 2,5 mm ²)	3P +N C16 (5G 2,5 mm ²)	3P +N C20 (5G 2,5 mm ²)	3P +N C20 (5G 2,5 mm ²)
Power Input Max (air 28°C)	3,4 kW	4,1 kW	6,0 kW	6,9 kW
Minimum water flow	5 m ³ /h	6 m ³ /h	10 m ³ /h	12 m ³ /h
Dimensions in mm (L x l x h)	1080 x 479 x 707	1080 x 479 x 707	1178 x 525 x 569	1167 x 498 x 1171
Weight net (gross)	62 kg (72 kg)	63 kg (80 kg)	94 kg (111 kg)	123 kg (143 kg)

CONTROL YOUR HEAT PUMP REMOTELY WITH THIS SWIMMING POOL HEAT PUMP WITH INTEGRATED FULL INVERTER TECHNOLOGY.

The **exclusive intelligent system** integrated into Master-Inverter heat pumps **regulates the output in relation to the water temperature but also takes into consideration the outside air temperature.** This guarantees heating performance at the best COP level and **lowest noise level.**



e.g.: simplified operation of the Master-Inverter heat pump in SMART mode

	Power	COP	Noise levels
Cold air and cold water	high	standard	standard
Cold air and warm water	average	average	low
Warm air and warm water	minimum	maximum	minimum



MASTER INVERTER XL Tri

ACCESSORIES INCLUDED

	
Winter cover	PVC fittings 1/2" unions Anti vibration feet



OTTIMO

- EXTREMELY LOW NOISE LEVEL
- INTUITIVE OPERATING MODES : BOOST, SMART & SILENCE
- HIGH-PERFORMANCE VARIABLE SPEED COMPRESSOR
- UP TO 30 TO 40 % MORE EFFICIENT COP
- OPERATES DOWN TO -10° C
- ECO-FRIENDLY R32 REFRIGERANT GAS
- ABS CASING WITH ANTI-UV PROTECTION
- POLYCONNECT INCLUDED
- 5-YEAR WARRANTY - PARTS AND LABOUR



	XS	S	S+	M	XM
PRODUCT CODE - E	IVP07-K3	IVP09-K3	IVP011-K3	IVP13-K3	IVP15-K3
PRICE GBP	£2,576	£3,167	£3,734	£4,544	£5,540



Features and benefits



SIMPLE AND INTUITIVE OPERATION

Color digital touch screen.

Three operating modes: Heating, Cooling and Automatic.



INTELLIGENT OPERATING MODE

PolySmart Control: the heat pump autoregulates its output depending on the water and air temperature.



OPTIMAL PERFORMANCES

Optimal Twist: Titanium heat exchanger in a PVC housing, efficient and corrosion resistant.



2D Technology: inverter compressor, higher COP thanks to the Hz by Hz variable speed motor.



DC Brushless: variable speed fan motor ensures optimal performance.



LOW NOISE LEVELS

Noise reduction insulation on all panels and rotation speed of the compressor and fan automatically adjusted to reduce noise to the minimum.



CONNECTED SOLUTION

PolyConnect inside : WiFi module included. Remote management with a smartphone and supervision by our Lighthouse Technical Center.



Reverse-cycle defrosting



ENERGY EFFICIENCY

- Full-Inverter Technology,
- Low impact R32 refrigerant,
- Enhanced COP.

Technical specifications

MODEL	OTTIMO XS	OTTIMO S	OTTIMO S+	OTTIMO M	OTTIMO XM
SCOP acc. to EN 17645	8,1	8,8	7,5	7,0	7,2
Classification acc. to EN 17645	A	A	A	A	A
Recommended pool size*	35-45 m ³	45-55 m ³	55-70 m ³	70-85 m ³	85-105 m ³
Air 26°C / Water 26°C / Humidity 80%					
Energy Output BOOST mode	9,5 kW	12,8 kW	15,3 kW	18,2 kW	20,1 kW
COP BOOST mode	6,2	6,2	6,3	6,2	6,1
Energy Output SMART mode	9,5 ~ 3,2 kW	12,8 ~ 3,5 kW	15,3 ~ 3,9 kW	18,2 ~ 4,2 kW	20,1 ~ 5,5 kW
COP SMART mode	6,2 ~ 10,8	6,2 ~ 10,8	6,3 ~ 10,8	6,2 ~ 11,2	6,1 ~ 10,8
Energy Output ECO-Silent mode	3,2 kW	3,5 kW	3,9 kW	4,2 kW	5,5 kW
COP ECO-Silent mode	10,8	10,8	10,8	11,2	10,8
Air 15°C / Water 26°C / Humidity 70%**					
Energy Output BOOST mode	6,9 kW	9,1 kW	11,0 kW	12,7 kW	14,5 kW
COP BOOST mode	4,7	4,6	4,7	4,6	4,5
Energy Output SMART mode	6,9 ~ 3,5 kW	9,1 ~ 3,9 kW	11,0 ~ 5,0 kW	12,7 ~ 7,1 kW	14,5 ~ 7,0 kW
COP SMART mode	4,7 ~ 6,4	4,6 ~ 6,6	4,69 ~ 6,5	4,6 ~ 6,6	4,5 ~ 6,6
Energy Output ECO-Silent mode	3,5 kW	3,9 kW	5,0 kW	7,1 kW	8,0 kW
COP ECO-Silent mode	6,4	6,6	6,5	6,6	6,6
Air 7°C / Water 26°C / Humidity 90%					
Energy Output BOOST mode	5,9 kW	7,2 kW	8,7 kW	10,1 kW	12,2 kW
COP BOOST Mode	4,2	3,9	4	4,1	3,93
Air -7°C / Water 26°C / Humidity 0%					
Energy Output BOOST Mode	3,4 kW	4,5 kW	5,42 kW	6,35 kW	7,25 kW
COP BOOST Mode	2,5	1,4	2,4	2,3	2,2
Noise level CTTM mini-maxi (at 10m) according to EN ISO 3741	31 ~ 33 dB(a)	24 ~ 34 dB(a)	27 ~ 37 dB(a)	28 ~ 38 dB(a)	29 ~ 38 dB(a)
Noise level min-max (at 10m) acc. to EN ISO 3744 : 2010	19 ~ 28 dB(a)	20 ~ 29 dB(a)	21 ~ 30 dB(a)	22 ~ 31 dB(a)	23 ~ 32 dB(a)
Temperature working range	-10°C -> 38°C				
Installation					
Hydraulic connexions	1,5"/50 mm				
Power	230 V / 1~+N / 50 Hz				
Circuit breaker and cable size (for 20 m)	C 16 A (3G 2,5 mm ²)	C 16 A (3G 2,5 mm ²)	C 16 A (3G 2,5 mm ²)	C 20 A (3G 4 mm ²)	C 20 A (3G 4 mm ²)
Power Input Max (air 26°C)	1,5 kW	2,4 kW	2,6 kW	3,3 kW	3,6 kW
Minmum water flow	3 m ³ /h	4 m ³ /h	5 m ³ /h	5 m ³ /h	6 m ³ /h
Dimensions in mm (L x l x h)	Ø 704 x 802				
Weight net (gross)	43 kg (62,8 kg)	45 kg (67 kg)	47 kg (68,2 kg)	55 kg (73,8 kg)	57 kg (74,4 kg)

CARE290

An eco-friendly swimming pool heat pump



INNOVATION !

The CARE290 heat pump **has been developed by our R&D department to make the most of the full-inverter technology while using a natural and ecological refrigerant.**

Beyond the current regulations in force, it prefigures the machine of tomorrow with **its innovative operation and high energy efficiency.** It is THE solution of tomorrow - available today - to reduce the carbon footprint of pool heating.

VERY HIGH ENERGY EFFICIENCY

- ✓ Environmentally friendly gas
- ✓ Excellent COP
- ✓ Control of energy consumption thanks to exclusive self-regulation
- ✓ Compatible with photovoltaic PolySolar Energy system
- ✓ Body made of recycled material
- ✓ A sharp and innovative design



Using of the natural refrigerant R290 (or propane) has many advantages:

- **Reliable, natural** and **environmentally neutral**, the physical properties of the natural and environmentally friendly R290 gas and its high energy efficiency make it possible to obtain an even better COP.
- The use of R290 propane also makes it possible to extend the range of operating temperatures (down to -25°C)
- It does not require authorisation in the event of intervention or refilling, nor does it require annual leakage checks. Moreover, R290 is not affected by the F-Gas regulations in force and the regulatory context which restricts the use of traditional fluids.

SAVE EVEN MORE ON YOUR ENERGY BILL WITH THE CARE290 HEAT PUMP IN COMBINATION WITH THE POLYSOLAR ENERGY SYSTEM PHOTOVOLTAIC PANEL KIT.

Ideal 'hybrid' solution with the installation of photovoltaic panels

Get the most out of your CARE290 swimming pool Heat pump by combining it with **photovoltaic panels the Polysolar Energy system.**

Energy consumption is thus optimized, almost entirely free of the electrical distribution network and self sustaining.

PROVIDES UP TO 90% OF THE CONSUMPTION NECESSARY TO ENSURE THE PROPER OPERATION OF YOUR SWIMMING POOL HEAT PUMP





CARE290

- EXTREMELY LOW NOISE LEVEL
- INTUITIVE OPERATING MODES : BOOST, SMART & SILENCE
- HIGH-PERFORMANCE VARIABLE SPEED COMPRESSOR
- UP TO 30 TO 40 % MORE EFFICIENT COP
- OPERATES DOWN TO -25° C
- ULTRA ECO-FRIENDLY R290 REFRIGERANT PROPANE GAS
- ABS CASING WITH ANTI-UV PROTECTION
- POLYCONNECT INCLUDED
- 5-YEAR WARRANTY - PARTS AND LABOUR



	Care290 S	Care290 S+	Care290 M	Care290 XM
PRODUCT CODE - E				
	IVR08-K2	IVR10-K2	IVR12-K2	IVR15-K2
PRICE GBP	£3,461	£4,040	£4,966	£6,008

Features and benefits



SIMPLE AND INTUITIVE OPERATION

Color digital touch screen.

Three operating modes:

Heating, Cooling and Automatic.



INTELLIGENT OPERATING MODE

PolySmart Control: the heat pump autoregulates its output depending on the water and air temperature.

OPTIMAL PERFORMANCE



Optimal Twist: Titanium exchanger in a PVC housing, efficient and corrosion resistant.



2D Technology: inverter compressor, higher COP thanks to the Hz by Hz variable speed motor.



DC Brushless: variable speed fan motor ensures optimal performance.



LOW NOISE LEVELS

Noise reduction insulation on all panels and rotation speed of the compressor and fan automatically adjusted to reduce noise to the minimum.



CONNECTED SOLUTION

PolyConnect inside : wifi module and 4G card included allowing for remote control and supervision from our Technicenter



EXCLUSIVE «LOW TEMPERATURE» SYSTEM

- Reverse-cycle defrosting,
- Preheating of the compressor housing,
- Antifreeze system for the evaporators condensation,
- Automatic piloting of the 'low temperature' system.



RECYCLED MATERIAL

Casing made from 70% recycled material and UV treated

ACCESSORIES INCLUDED : winter cover, 50 mm hydraulic connection kit, 4 «Silent block» anti-vibration pads, condensate drainage kit, multilingual user and maintenance manual.

Technical specifications

1-PHASE MODEL	CARE290 S	CARE290 S+	CARE290 M	CARE290 XM
SCOP according to EN 17645	7,7	7,9	7,4	7,2
Classification acc. to EN 17645	A	A	A	A
Recommended pool size*	45-55 m ³	55-70 m ³	70-85 m ³	85-105 m ³
Air 26°C / Water 26°C / Humidity 80%				
Energy Output BOOST mode	10,4 kW	13,1 kW	14,8 kW	20,5 kW
COP BOOST Mode	6,9	6,9	5,9	5,9
Energy Output SMART mode	10,4 ~ 3,1 kW	13,1 ~ 5,4 kW	14,8 ~ 6,5 kW	20,5 ~ 8,2 kW
COP SMART Mode	10,4 ~ 6,9	11,2 ~ 6,9	10,3 ~ 5,9	9,9 ~ 5,9
Energy Output ECO-Silence mode	3,1 kW	5,4 kW	6,5 kW	8,2 kW
COP ECO-Silence Mode	10,4	11,2	10,3	9,9
Air 15°C / Water 26°C / Humidity 70%**				
Energy Output BOOST mode	7,9 kW	10,2 kW	12,1 kW	14,8 kW
COP BOOST Mode	5,6	5,3	5,0	5,2
Energy Output SMART mode	7,9 ~ 2,8 kW	10,2 ~ 4,5 kW	12,1 ~ 5 kW	14,8 ~ 8,1 kW
COP SMART Mode	7 ~ 5,6	7,5 ~ 5,3	7 ~ 5	6,7 ~ 5,2
Energy Output ECO-Silence mode	2,8 kW	4,5 kW	5,0 kW	8,1 kW
COP ECO-Silence Mode	7,0	7,5	7,0	6,7
Air -15°C / Water 26°C / Humidity 0%				
Energy Output BOOST mode	3,2 kW	3,9 kW	4,5 kW	5,9 kW
COP BOOST Mode	2,7	2,2	2,3	2,3
Noise level min-max (at 10m) CTTM certified acc. to EN ISO 3741 : 2010 ***	27 ~ 29 dB(a)	27 ~ 30 dB(a)	28 ~ 32 dB(a)	28 ~ 33 dB(a)
Noise level min-max (at 10m) acc. to EN ISO 3744 : 2010	22 ~ 25 dB(a)	25 ~ 28 dB(a)	25 ~ 29 dB(a)	26 ~ 29 dB(a)
Temperature working range	-25°C > 38°C			
Installation				
Hydraulic connections	1,5" / 50 mm			
Power	230V / 1~+N / 50 Hz			
Circuit breaker and cable size (for 20 m)	C 16 A (3G 2,5mm ²)	C 16 A (3G 2,5mm ²)	C 25 A (3G 4,0mm ²)	C 25 A (3G 4,0mm ²)
Power Input Max (air 28°C)	2,3 kW	3,0 kW	3,5 kW	3,9 kW
Minimum water flow	3 m ³ /h	4 m ³ /h	5 m ³ /h	6 m ³ /h
Dimensions in mm (L x l x h)	1145 x 454 x 889	1145 x 454 x 889	1145 x 454 x 939	1145 x 454 x 939
Weight net (gross)	65 kg (76 kg)	70 kg (82 kg)	86 kg (96 kg)	91 kg (102 kg)

* May to September with cover.

** Tests run with air temperature of 59°F, water inlet temperature of 78.8°F and water outlet temperature of 82.4°F in order to define the required water flow, heating capacity and consumption. In accordance with FPP recommendations (French Pool Federation).

***The BOOST and ECO mode noise levels at 10.9 yards are certified by the independent testing laboratory of Centre de Transfert de Technologie du Mans (CTTM) according to EN ISO 3741 : 2010.

RAK INVERTER

For commercial and large pools

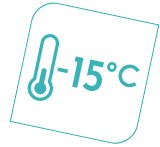

Video Demo



REDUCE ENERGY BILLS AND CONTROL NOISE LEVELS

With this full-Inverter technology reversible high-power heat pump specially designed for large sized pools.

The exclusive intelligent system integrated into RAK Inverter heat pumps **regulates the output** in relation to the water temperature but also takes into consideration the outside air temperature. This guarantees **heating performance** at the **best COP** and **lowest noise level!**



An exclusive system

EASY INSTALLATION AND CUSTOMIZED SOLUTION

- Installation is made easy with this compact heat pump and its standard electrical connection.
- RAK Inverters can be installed in series, whilst being controlled from a single remote display
- The regulation system optimises the operating time of each unit.

Up to 16 units can be connected depending on the needs and volume of the pool.

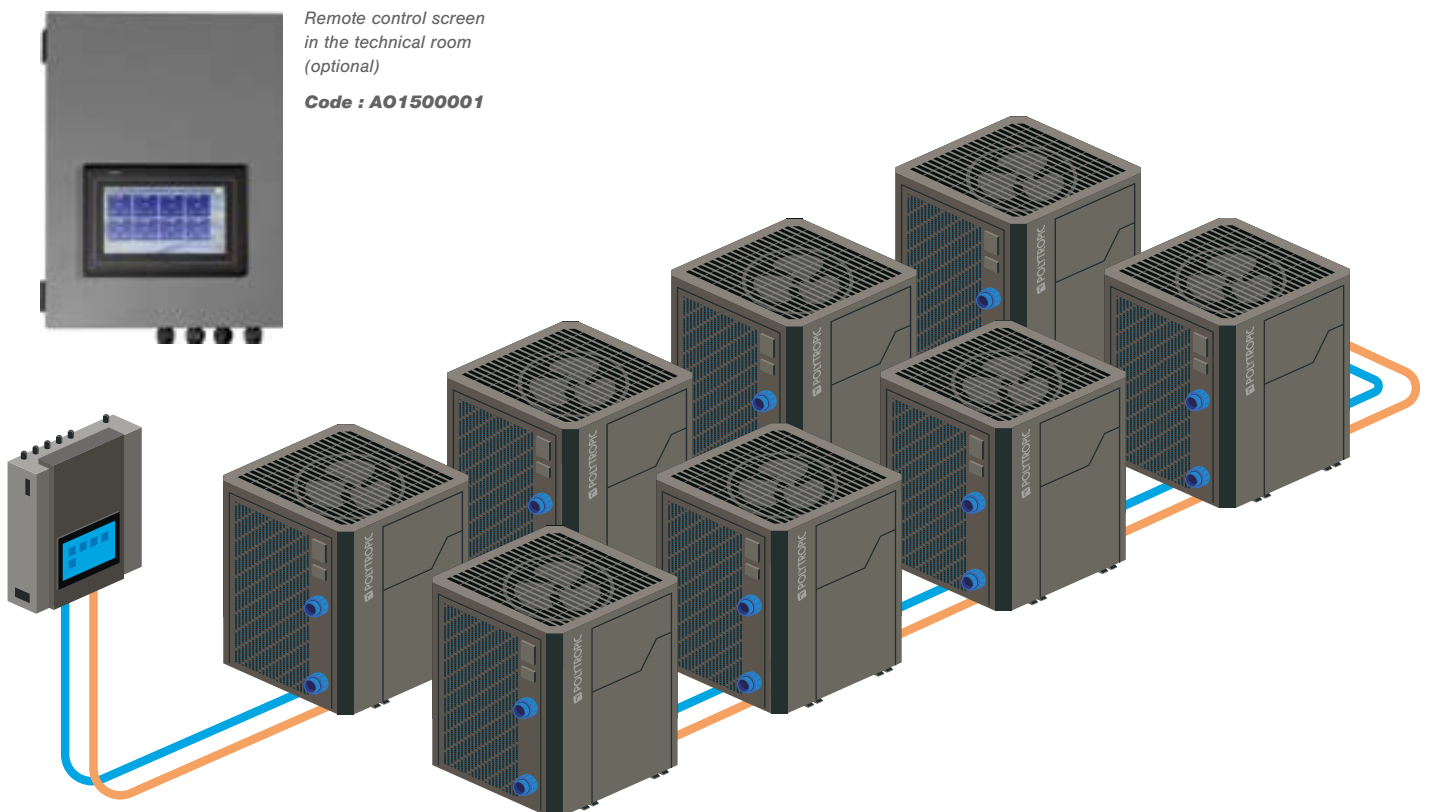

Remote control screen
in the technical room
(optional)

Code : AO1500001



RAK INVERTER

- EXTREMELY LOW NOISE LEVEL
- INTUITIVE OPERATING MODES : BOOST, SMART & SILENCE
- HIGH-PERFORMANCE VARIABLE SPEED COMPRESSOR
- UP TO 30 TO 40 % MORE EFFICIENT COP
- OPERATES DOWN TO -15° C
- ECO-FRIENDLY R32 REFRIGERANT GAS
- POWDER COATED CASING WITH ANTI-UV PROTECTION
- POLYCONNECT INCLUDED
- 5-YEAR WARRANTY



	RAK 35	RAK 45	RAK 90
PRODUCT CODE - E	RAK35IVT	RAK45IVT	RAK90IVT
PRICE GBP	£13,069	£16,194	£31,241

Features and benefits



SIMPLE AND INTUITIVE OPERATION

Color digital touch screen.

Three operating modes: heating, Cooling and Automatic.



INTELLIGENT OPERATING MODE

PolySmart Control: the heat pump autoregulates its output depending on the water and air temperature.



INSTALLATION

Several units (up to 16) can be connected Master controller to be ordered as an option.



OPTIMAL PERFORMANCES

Optimal Twist: Titanium exchanger in a PVC housing, efficient and corrosion resistant.



2D Technology: inverter compressor, higher COP thanks to the Hz by Hz variable speed motor.



EXCLUSIVE «LOW TEMPERATURE» SYSTEM

- Reverse-cycle defrosting,
- Preheating of the compressor housing
- Antifreeze system for the evaporators condensation
- Automatic piloting of the 'low temperature' system.



COMMISSIONING AND WINTERING

The technical start-up and the 1st wintering of the machine can be carried out on request by dedicated POLYTROPIC technicians.



DC Brushless: variable speed fan motor ensures optimal performance.



OPTIMAL COP

An efficient electronic expansion valve which regulates the flow of refrigerant gas in accordance with the weather conditions.



CONNECTED SOLUTION

PolyConnect inside: wifi module and 4G key included for remote control via smartphone and permanent supervision by the Technicenter.

Accessories included: winter cover, hydraulic connection kit, multilingual user and maintenance manual

Technical specifications

3-PHASE MODELS	RAK35 IVT	RAK45 IVT	RAK90 IVT
SCOP according to EN 17645	7,1	7,1	7,2
Classification according to EN 17645	A	A	A
Air 26°C / Water 26°C / Humidity 80%			
Energy Output BOOST mode	41,5 kW	56,8 kW	103,2 kW
COP BOOST mode	6,1	5,6	5,2
Energy Output SMART mode	41,5 ~ 24,1 kW	56,8 ~ 24,4 kW	103,2 ~ 39,1 kW
COP SMART mode	6,1 ~ 10,2	5,6 ~ 10,2	10,2 ~ 5,2
Energy Output SMART ECO-Silence mode	24,1 kW	24,4 kW	39,1 kW
COP ECO-Silence mode	10,2	10,2	10,1
Air 15°C / Water 26°C / Humidity 70%*			
Energy Output BOOST mode	35,6 kW	43,7 kW	84,1 kW
COP BOOST mode	4,6	4,4	4,5
Energy Output SMART mode	35,6 ~ 18,0 kW	43,7 ~ 18,2 kW	84,1 ~ 31,9 kW
COP SMART mode	7,2 ~ 4,6	7,1 ~ 4,4	6,5 ~ 4,5
Energy Output SMART ECO-Silence mode	18,0 kW	18,2 kW	31,9 kW
COP ECO-Silence mode	7,2	7,1	6,5
Air 7°C / Water 26°C / Humidity 90%			
Energy Output BOOST mode	28,5 kW	32,9 kW	63,7 kW
COP BOOST mode	3,7	3,4	3,2
Air -7°C / Water 26°C / Humidity 0%			
Energy Output BOOST mode	17,8 kW	21,9 kW	40,4 kW
COP BOOST mode	2,8	2,7	2,4
Noise level CTTM mini-maxi (at 10m) according to EN ISO 3741 : 2010 **	46 ~ 49 dB(a)	46 ~ 51 dB(a)	-
Maximum noise level (at 10m) according to EN ISO 3744: 2010	39 dB(a)	44 dB(a)	49 dB(a)
Temperature working range	-15°C - 43°C		
Installation			
Hydraulic connexions	63 mm		Flange 90 mm
Power	400 V / 3~+N / 50 Hz		
Circuit breaker and cable size (for 20 m)	3P +N C 25 A (5G*4 mm ²)	3P +N C 32 A (5G*6 mm ²)	3P +N C 50 A (5G*10 mm ²)
Power Input Max (air 26°C)	6,8 kW	10,1 kW	25,0 kW
Minmum water flow	12 m ³ /h	15 m ³ /h	38 m ³ /h
Dimensions in mm (L x l x h)	1050 x 1050 x 1260		2000 x 980 x 1960
Weight net (gross)	207 kg (264 kg)		530 kg (620 kg)

* Tests run with air temperature of 15°C, water inlet temperature of 26°C and water outlet temperature of 28°C in order to define the required water flow, heating capacity and consumption. In accordance with FPP recommendations (French Pool Federation).

**The BOOST and ECO mode noise levels at 10 m are certified by the independent testing laboratory CTTM according to EN ISO 3741 : 2010.

***Noise levels in BOOST and ECO mode at 10 m, certified by the independent laboratory Centre de Transfert de Technologie du Mans, according to EN ISO 3741: 2010



SPA INVERTER

- HEATS SPAS UP TO 38° C
- INTUITIVE OPERATING
- HIGH-PERFORMANCE VARIABLE SPEED COMPRESSOR
- UP TO 30 TO 40 % MORE EFFICIENT COP
- OPERATES DOWN TO -10° C
- ECO-FRIENDLY R32 REFRIGERANT GAS
- ABS CASING WITH ANTI-UV PROTECTION
- POLYCONNECT INCLUDED
- 5-YEAR WARRANTY - PARTS AND LABOUR



POLYCONNECT2.0



SPA INVERTER	
PRODUCT CODE - E	IVZ10-SPA
PRICE GBP	£ 2,782



Features and benefits



SIMPLE AND INTUITIVE

An intelligent display.



INTELLIGENT OPERATING MODE

PolySmart Control: the heat pump autoregulates its output depending on the water and air temperature.



OPTIMAL PERFORMANCES

Optimal Twist: Titanium heat exchanger in a PVC housing, efficient and corrosion resistant.

2D Technology: inverter



compressor, higher COP thanks to the Hz by Hz variable speed motor.



LOW NOISE LEVEL

Automatically adjusts the rotation speed of the compressor and fan to reduce noise to the minimum.



CONNECTED SOLUTION

PolyConnect inside : WiFi module included. Remote management with a smartphone and supervision by our Tech Center.



DC Brushless: variable speed fan motor ensures optimal performance.



ENERGY EFFICIENCY

- Full-Inverter Technology,
- Low impact R32 refrigerant,
- Enhanced COP.



EXCLUSIVE 'LOW TEMPERATURE' SYSTEM

- Reverse-cycle defrosting,
- Preheating of the compressor housing,
- Antifreeze system of the evaporator condensation,
- Automatic piloting of the low temperature system

Accessories included: winter cover, 50 mm hydraulic connection kit, «Silent block» anti-vibration pads, condensate drainage kit, maintenance

Technical specifications

MODEL	SPA INVERTER
Air 28°C / Water 38°C / Humidity 80%	
Energy output	9,8 kW
COP BOOST mode	4,9
Air 15°C / Water 38°C / Humidity 70%	
Energy output BOOST mode	7,5 kW
COP BOOST mode	3,6
Air 0°C / Water 38°C / Humidity 0%	
Energy output BOOST mode	4,0 kW
COP BOOST mode	2,0
Air -10°C / Water 38°C / Humidity 0%	
Energy output BOOST mode	3,1 kW
COP BOOST Mode	1,6
Noise level min-max (at 10 m) CTTM certified*	26 ~ 32 dB(a)
Noise level min-max (10 m) acc. EN ISO 3744 : 2010	23 ~ 29 dB(a)
Temperature working range	-10°C - 38°C
Installation	
Hydraulic connection	1,5" / 50 mm
Power	230V / 1~+N / 50 Hz
Maximal intensity	6,3 A (7,8A)
Breaker and cable size for 20 m with D curve	C16 A (3G 2,5 mm ²)
Maximum power input	2 kW
Minimal water flow	4 m ³ /h
Dimensions in mm (L x W x H)	936 x 322 x 567
Weight (net)	47 kg





STPIO

- HEATS SPAS UP TO 38° C
- DISCREETLY INTEGRATED
- HIGH-PERFORMANCE VARIABLE SPEED COMPRESSOR
- UP TO 30 TO 40 % MORE EFFICIENT COP
- OPERATES DOWN TO -10° C
- ECO-FRIENDLY R32 REFRIGERANT GAS
- ABS CASING WITH ANTI-UV PROTECTION
- POLYCONNECT INCLUDED
- 5-YEAR WARRANTY



	STPIO
PRODUCT CODE - E	STPIO
PRICE GBP	£ 2,749

DISCREETLY INTEGRATED IN A STAIRCASE, STEPIO HEAT PUMP GUARANTEES A SPA HEATED AT 38°C (100°F).

When wellbeing and energy savings are in sync.



Features and benefits



SIMPLE AND INTUITIVE

An intelligent display. **Remote wall control kit in option**



SMART TECHNOLOGY

PolySmart Control: automatically adjusts output and adjusts to air and water temperature



OPTIMAL PERFORMANCES

Optimal Twist: Titanium heat exchanger in a PVC housing, efficient and corrosion resistant.



2D Technology: inverter compressor, higher COP thanks to the Hz by Hz variable speed motor.



LOW NOISE LEVEL

Automatically adjusts the rotation speed of the compressor and fan to reduce noise to the minimum.



CONNECTED

PolyConnect inside : includes a WIFI that allows you to manage your system from your smartphone and have supervision from the TechniCenter. **4G in option.**



DC Brushless: variable speed fan motor ensures optimal performance.



ENERGY EFFICIENCY

- Full-Inverter Technology,
- Low impact R32 refrigerant,
- Enhanced COP.



EXCLUSIVE COLD ENVIRONMENT SYSTEM

- Reverse-cycle defrosting,
- Preheating of the compressor housing,
- Antifreeze system of the evaporator condensation,
- Automatic piloting of the low temperature system

STEPSIO	
Air 28°C / Water 38°C / 80%HR	
Energy Output	6,5 kW
COP	4,6
Air 15°C / Water 38°C / 70%HR	
Energy Output	4,4 kW
COP	3,4
Air 15°C / Water 26°C / 0%HR	
Energy Output	5,2 kW
COP	4,6
Air -10°C / Water 38°C / 0%HR	
Energy Output	1,1 kW
COP	0,9
Noise level (10 m) acc. EN ISO 3744 : 2010	29 dB(a)
Temperature working range	-10°C - 38°C
Components	
Compressor	2D Full DC 
Expansion valve	Electronic
Exchanger	Coiled Titanium
Housing	UV resistant ABS housing panels
Refrigerant	R32
Installation	
Hydraulic connection	1,5" / 50 mm
Power	230V / 1~+N / 50 Hz
Maximal intensity	6,2 A (7,6 A)
Breaker and cable size for 20 m with D curve	C10 A (3G 2,5 mm ²)
Minimal water flow	3 m ³ /h
Dimensions (L x W x H)	750 x 375 x 490 mm
Weight (net)	47 kg





CRYO INVERTER CHILLER

- WORKS DOWN TO -10° C
- COOLS WATER DOWN TO 5° C
- HIGH-PERFORMANCE VARIABLE SPEED COMPRESSOR
- UP TO 30 TO 40 % MORE EFFICIENT COP
- ECO-FRIENDLY R32 REFRIGERANT GAS
- ABS CASING WITH ANTI-UV PROTECTION
- POLYCONNECT INCLUDED
- 5-YEAR WARRANTY - PARTS AND LABOUR



POLYCONNECT 2.0



CRYO INVERTER	
PRODUCT CODE - E	CRYO
PRICE GBP	£ 3,058



Thanks to the Full-Inverter technology, the CRYO PAC adjusts its operation according to the pool requirements: giving peace of mind, extension of the equipment's lifespan and 30% energy savings compared to a standard heat pump.

- Conventional installation like a standard pool heat pump
- Anti-UV ABS casing

Features and benefits



SIMPLE AND INTUITIVE

An intelligent display.



INTELLIGENT OPERATING MODE

PolySmart Control: the heat pump autoregulates its output depending on the water and air temperature.



OPTIMAL PERFORMANCES

- BlueFins evaporator for a better corrosion resistance and better evacuation of the condensation (hydrophobic)



- Titanium exchanger in PVC housing, efficient and corrosion resistant



DC Brushless: variable speed fan motor ensures optimal performance.



EXCLUSIVE «LOW TEMPERATURE» SYSTEM

- Reverse-cycle defrosting,
- Preheating of the compressor housing,
- Antifreeze system for the evaporators condensation,
- Automatic piloting of the 'low temperature' system.

Accessories included: winter cover, 50 mm hydraulic connection kit, «Silent block» anti-vibration pads, condensate drainage kit, maintenance manual.

Technical specifications

MODEL	CRYO INVERTER
Air 32°C / Water 5°C	
Energy Input BOOST mode	3,8 kW
Energy Efficient Ratio (EER)	2,7
Noise level min-max (at 10 m) CTTM certified*	28 ~ 35 dB(a)
Noise level min-max (10 m) acc. EN ISO 3744 : 2010	25 ~ 32 dB(a)
Temperature working range	-10°C -> 35°C
Installation	
Hydraulic connections	1,5"/50 mm
Power	230V / 1~+N / 50 Hz
Intensity (maximum)	6,3 A (7,8 A)
Breaker and cable size	C16 A (3G*2,5 mm²)
Minimum water flow	4 m³/h
Dimensions in mm (L x W x H)	936 x 322 x 567
Weight (net)	33kg





POLYSOLAR

- PV SOLAR SYSTEM FOR POOLS
- DESIGNED FOR POOL HEAT PUMPS
- REDUCE POOL RUNNING COSTS
- COMPLETE SYSTEM
- ROOF AND FLOOR INSTALLATION OPTIONS
- EXCLUSIVE TO LIGHTHOUSE
- 20YRS WARRANTY ON PANLES
- POLYCONNECT INCLUDED



 POLYCONNECT2.0



SLOPING ROOF INSTALLATION PANEL QTY	4	5	6	7	8	9	10
PRODUCT CODE - G							
	POLYS 4 RF	POLYS 5 RF	POLYS 6 RF	POLYS 7 RF	POLYS 8 RF	POLYS 9 RF	POLYS 10 RF
PRICE GBP	£5,073	£5,805	£6,406	£7,138	£7,739	£8,780	£9,380

FLOOR OR FLAT ROOF INSTALLATION PANEL QTY	4	5	6	7	8	9	10
PRODUCT CODE - G							
	POLYS 4 FL	POLYS 5 FL	POLYS 6 FL	POLYS 7 FL	POLYS 8 FL	POLYS 9 FL	POLYS 10 FL
PRICE GBP	£5,073	£5,805	£6,406	£7,138	£7,739	£8,780	£9,380

Features and benefits



Financial gain: The PolySolar Energy System can produce up to 100% of the energy required to drive the swimming pool heat pump. When the desired set point temperature has been achieved, the energy supplied by the panels is consumed by the other electrical appliances in the house and contributes to the overall profitability of the system.



Performance: high-efficiency solar cells convert the entire solar radiation thanks to their high-performance coating.



Easy: plug & play installation on any pool house roof or in a south facing garden. The kit is very easy to connect by a qualified electrician.



Warranty: French photovoltaic panel manufacturer, 15 years product warranty. 85% photovoltaic yield guaranteed after 25 years.

Imagine powering your pool for free using the power of the sun and the air!

The photovoltaic solution



INNOVATION !

Get the most out of your swimming pool Heat Pump by combining it with photovoltaic panels and the Polysolar Energy System.

Energy consumption is thus optimized almost entirely free of the electrical distribution network and self sustaining. Providing up to 100% of the consumption necessary to ensure the proper operation of your swimming pool heat pump*.

Reduced electricity bill and savings

Combining the Polytrropic heat pump with the **PolySolar Energy system** is a worthwhile investment and offers many advantages.

By converting solar radiation into electricity, each photovoltaic panel **optimally supplies the pool heat pump with up to the full required power** (depending on the number of modules, exposure and geographical location), while the remaining consumption is covered by the conventional electricity grid.



*depending on model and number of panels

Electricity consumption is then optimised by being partially freed from the network and allowing self-production and self-consumption.

When the water in the pool has reached 28°C, **the surplus energy production can supply the rest of the pool equipment, and also the home!**

The user can also choose to continue operating the heat pump in order to use the pool as an indirect energy storage in the form of calories.

POLYSOLAR SIZING

*Indicative data on the annual production of the panel, according to exposure and supplier rates. Polytronic is not responsible for this information

	Panels	Max Output (W)	XS (1.5kW)	S (2.4kW)	S+ (2.6kW)	M (3.3kW)	XM (3.6kW)	L (4.6kW)	L+ (6.0kW)
PolyS 2 RF	2	860	57%						
PolyS 3 RF	3	1290	86%	54%					
PolyS 4 RF	4	1720	115%	72%	66%	52%			
PolyS 5 RF	5	2150		90%	83%	65%	60%		
PolyS 6 RF	6	2580		108%	99%	78%	72%	56%	
PolyS 7 RF	7	3010			116%	91%	84%	65%	50%
PolyS 8 RF	8	3440				104%	96%	75%	57%
PolyS 9 RF	9	3870				117%	108%	84%	65%
PolyS 10 RF	10	4300						93%	72%

Technical specifications

Item reference	Name	kit contents	Peak power output
PolyS 4 RF	Pack PolySolar Energy System 4 panel ROOF	4 PV panel, 1 micro-inverter, 1 Polysolar control box, fixings: 2 rails 4 hooks 4 clamps (+ accessories)	1.72 kWc
PolyS 5 RF	Pack PolySolar Energy System 5 panels ROOF	5 PV panels, 1 micro-inverter, 1 Polysolar control box, fixings: 2 rails 4 hooks 6 clamps (+ accessories)	2.15 kWc
PolyS 6 RF	Pack PolySolar Energy System 6 panels ROOF	6 PV panels, 1 micro-inverter, 1 Polysolar control box, fixings : 2 rails 6 hooks 8 clamps (+ accessories)	2.58 kWc
PolyS 7 RF	Pack PolySolar Energy System 7 panels ROOF	7 PV panels, 1 micro-inverter, 1 Polysolar control box, fixings : 4 rails 2 junctions 8 hooks 12 clamps (+ accessoires)	3.01 kWc
PolyS 8 RF	Pack PolySolar Energy System 8 panels ROOF	8 PV panels, 1 micro-inverters, 1 Polysolar control box, fixings : 4 rails 2 junctions 12 hooks 16 clamps (+ accessories)	3.44 kWc
PolyS 9 RF	Pack PolySolar Energy System 9 panels ROOF	9 PV panels, 1 micro-inverters, 1 Polysolar control box, fixings : 8 rails 4 junctions 16 hooks 22 clamps (+ accessories)	3.87 kWc
PolyS 10 RF	Pack PolySolar Energy System 10 panels ROOF	10 PV panels, 1 micro-inverters, 1 Polysolar control box, fixings : 8 rails 4 junctions 16 hooks 22 clamps (+ accessories)	4.3 kWc

Installation

Installation on any pool house roof or in a south facing garden:

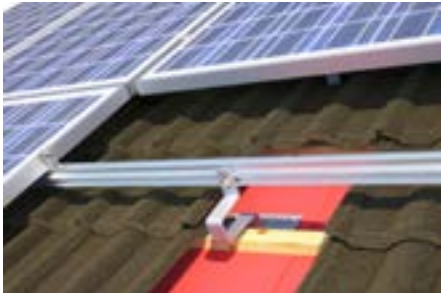

Roofing installation accessories



Accessories for deck or flat roof

Installed on the roof of the pool house or directly in a South facing garden and connected by an electrician with a standard electrical licence

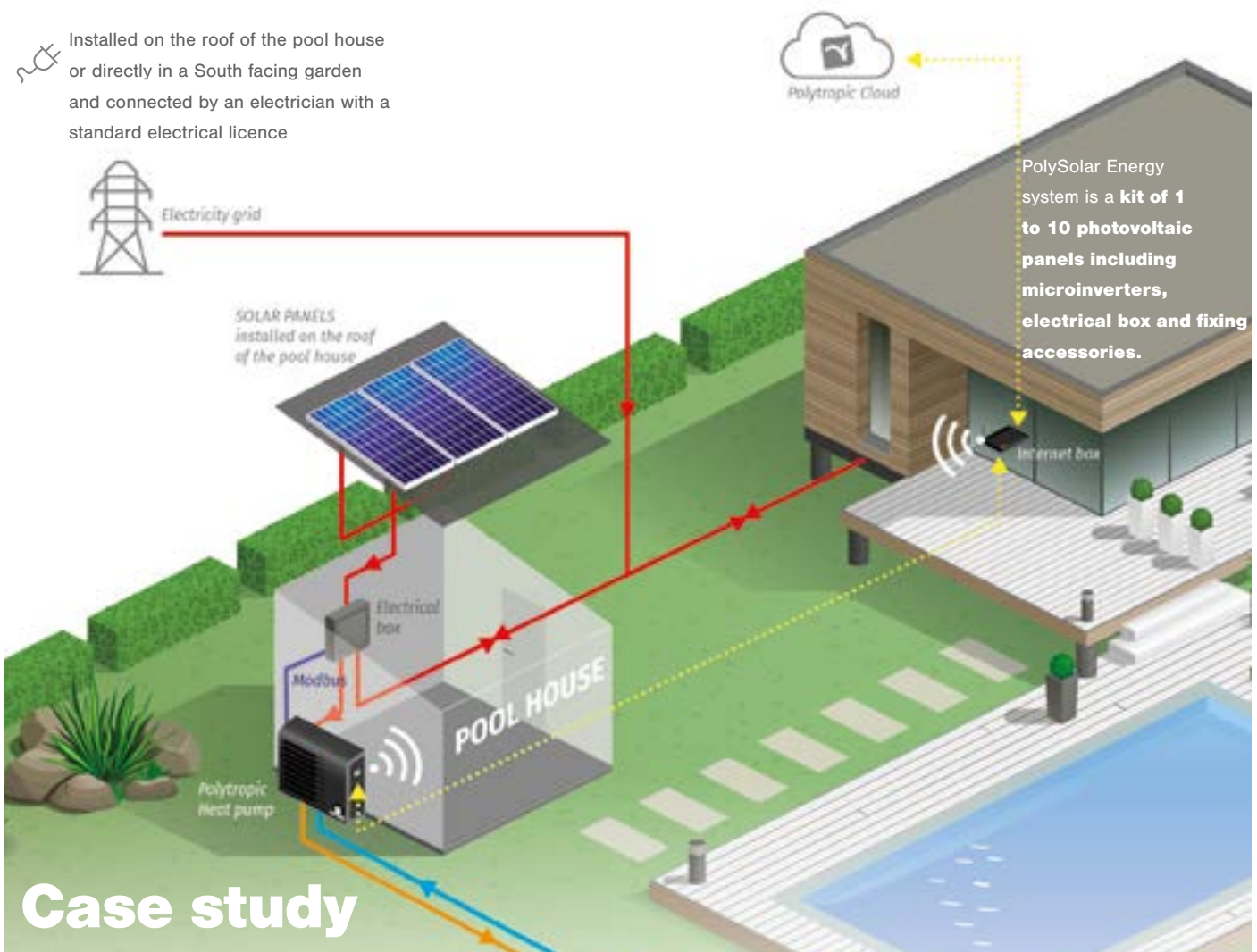

Covered swimming pool of **8 m x 4 m**, 1.5 m deep, in the Cambridge area, heated with a **set temperature of 28°C** by a swimming pool heat pump Master-Inverter S by POLYTROPIC, combined with the Polysolar Energy System from 15 May to 15 September:

with a 4 panels pack

> 100% of the electricity consumption of the heat pump during the season is provided by the production of the photovoltaic panel kit

with a 8 panels pack

> 100% of the electricity consumption of the heat pump AND the filtration pump during the season is provided by the production of the photovoltaic panel kit*.



Nano Spa

- AVAILABLE, RANGING FROM 1-kW TO 8-kW
- EASY INSTALLATION, FULLY EQUIPPED AND PRE-WIRED
- ROBUST, DURABLE CONSTRUCTION AND COMPACT DESIGN
- ULTRA-RELIABLE FLOW SWITCH FOR SAFE OPERATION
- FITTED WITH TEMPERATURE THERMOSTAT AND OVERHEATING SENSOR
- ANALOGUE CONTROL WITH 1.2°C DIFFERENTIAL
- TITANIUM FLOW TUBE AND TITANIUM HEATING ELEMENT
- VORTEX, LONG LIFE, STAY CLEAN HEATING ELEMENT TECHNOLOGY
- 100% EFFICIENCY THROUGHOUT THE PRODUCT LIFE
- SEA AND SALT CHLORINATED WATER COMPATIBLE
- CAN BE FLOOR OR VERTICALLY WALL MOUNTED
- SILENT OPERATION

ELEGR0
ENGINEERING



	1 kW	2 kW	3 kW	4 kW	5 kW	6 kW	8 kW 3 Phase
PRODUCT CODE - F	N-SPA-T1-R	N-SPA-T2-R	N-SPA-T3-R	N-SPA-T4-R	N-SPA-T5-R	N-SPA-T6-R	N-SPA-T8-R
PRICE GBP	£ 428	£ 435	£ 441	£ 447	£ 453	£ 459	£ 472

TECHNICAL SPECIFICATIONS	
Power Supply	Single phase or 3- phase
Min. flow rate	1m3/h
Max. flow rate	17 m3/h
Heating Element	Grade 1 titanium
Flow Tube	Grade 1 titanium
Control Thermostat	Analogue: 0 > 45°C (1.2°C differential)
Safety Thermal Cutout	60°C (manual reset)
Flow switch	Gold tipped reed switch with titanium fulcrum pin
Water Connections	1½" BSP female thread supplied with 1½"/50mm stepped ABS unions
Working Pressure	4 bar maximum
Protection rating	IP44
Mounting	Floor or wall mounting

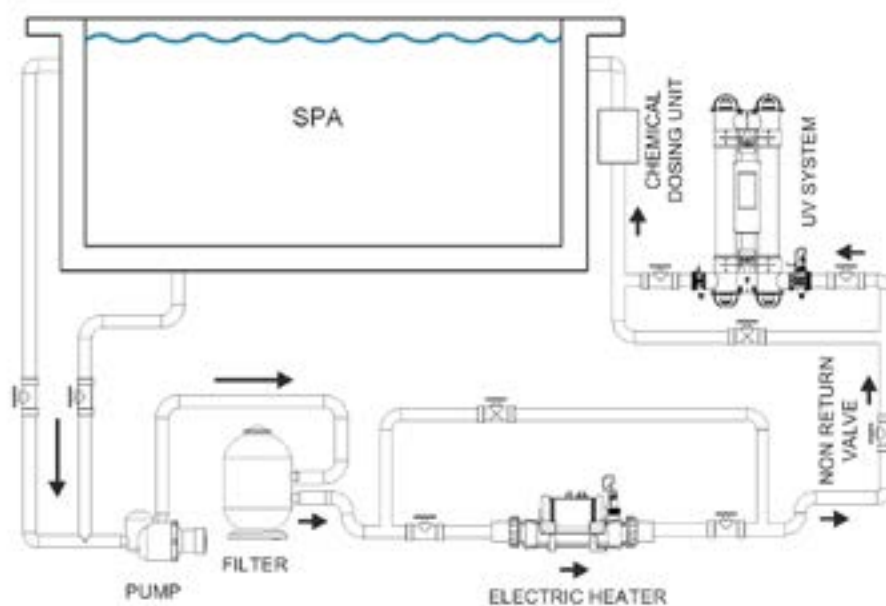



Nano Splasher

- AVAILABLE, RANGING FROM 2-kW TO 3-kW
- EASY INSTALLATION, FULLY EQUIPPED AND PRE-WIRED
- ROBUST, DURABLE CONSTRUCTION AND COMPACT DESIGN
- ULTRA-RELIABLE FLOW SWITCH FOR SAFE OPERATION
- FITTED WITH TEMPERATURE THERMOSTAT AND OVERHEATING SENSOR
- ANALOGUE CONTROL WITH 1.2°C DIFFERENTIAL
- TITANIUM FLOW TUBE AND TITANIUM HEATING ELEMENT
- VORTEX, LONG LIFE, STAY CLEAN HEATING ELEMENT TECHNOLOGY
- 100% EFFICIENCY THROUGHOUT THE PRODUCT LIFE
- SEA AND SALT CHLORINATED WATER COMPATIBLE
- CAN BE FLOOR OR VERTICALLY WALL MOUNTED
- SILENT OPERATION



	2 kW	3 kW
PRODUCT CODE - F	N-AGP-UK-T2	N-AGP-UK-T3
PRICE GBP	£ 383	£ 391

TECHNICAL SPECIFICATIONS	
Power Supply	Single phase
Min. flow rate	1m3/h
Max. flow rate	17 m3/h
Heating Element	Grade 1 titanium
Flow Tube	Grade 1 titanium
Control Thermostat	Analogue: 0 > 45°C (1.2°C differential)
Safety Thermal Cutout	60°C (manual reset)
Flow switch	Gold tipped reed switch with titanium fulcrum pin
Water Connections	1½" BSP female thread supplied with 1½"/50mm stepped ABS unions
Working Pressure	4 bar maximum
Protection rating	IP44
Mounting	Floor or wall mounting

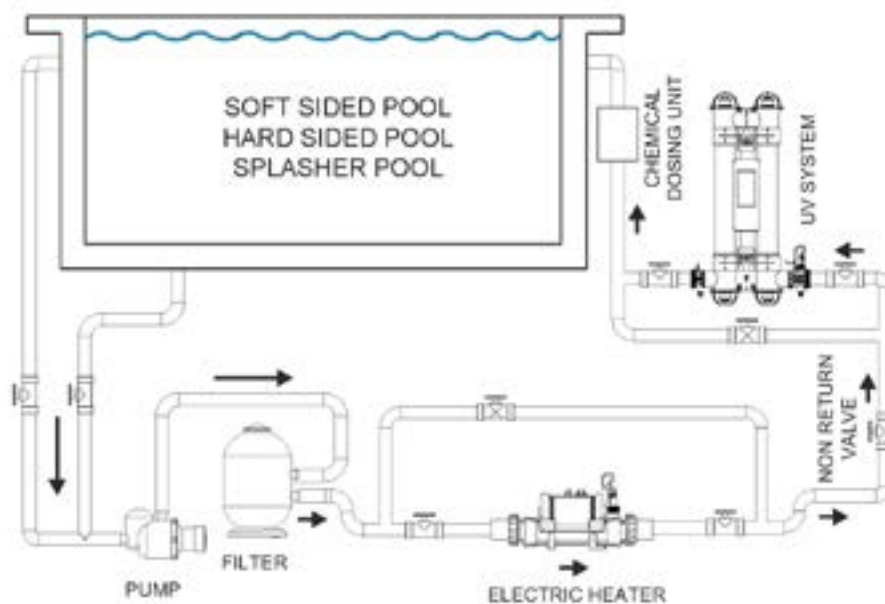



Evolution 2 ALL TITANIUM

- 23 MODELS AVAILABLE, RANGING FROM 1-kW TO 24-kW
- EASY INSTALLATION, FULLY EQUIPPED AND PRE-WIRED
- ROBUST, DURABLE CONSTRUCTION AND COMPACT DESIGN
- ULTRA-RELIABLE FLOW SWITCH FOR SAFE OPERATION
- FITTED WITH TEMPERATURE THERMOSTAT AND OVERHEATING SENSOR
- ANALOGUE CONTROL WITH 1.2°C DIFFERENTIAL OR DIGITAL CONTROL
- WITH 0.5°C DIFFERENTIAL AND SELECTABLE MULTI-LINGUAL DISPLAY
- TITANIUM FLOW TUBE AND TITANIUM HEATING ELEMENT
- VORTEX, LONG LIFE, STAY CLEAN HEATING ELEMENT TECHNOLOGY
- 100% EFFICIENCY THROUGHOUT THE PRODUCT LIFE
- SEA AND SALT CHLORINATED WATER COMPATIBLE
- CAN BE FLOOR OR VERTICALLY WALL MOUNTED
- SILENT OPERATION



	3 kW	4.5 kW	6 kW	9 kW	12 kW	15 kW	18 kW
PRODUCT CODE - F	E2-1-3	E2-1-4	E2-1-6	E2-1-9	E2-1-12	E2-1-15	E2-1-18
PRICE GBP	£ 640	£ 648	£ 656	£ 707	£ 730	£ 829	£ 908

	15 kW 3 Phase	18 kW 3 Phase	24 kW 3 Phase
PRODUCT CODE - F	E2-3-15	E2-3-18	E2-3-24
PRICE GBP	£ 829	£ 920	£ 960

TECHNICAL SPECIFICATIONS	
Power Supply	Single phase or 3-phase
Min. flow rate	Up to 3-kW: 1m3/hr, 4-kW to 6-kW: 1.5m3/hr, 8.4-kW & greater: 4m3/hr
Max. flow rate	17 m3/h
Heating Element	Grade 1 titanium
Flow Tube	Grade 1 titanium
Control Thermostat	Analogue: 0 > 45°C (1.2°C differential)
Safety Thermal Cutout	60°C (manual reset)
Flow switch	Gold tipped reed switch with titanium fulcrum pin
Water Connections	1½" BSP female thread supplied with 1½"/50mm stepped ABS unions
Working Pressure	4 bar maximum
Protection rating	IP44
Mounting	Floor or wall mounting

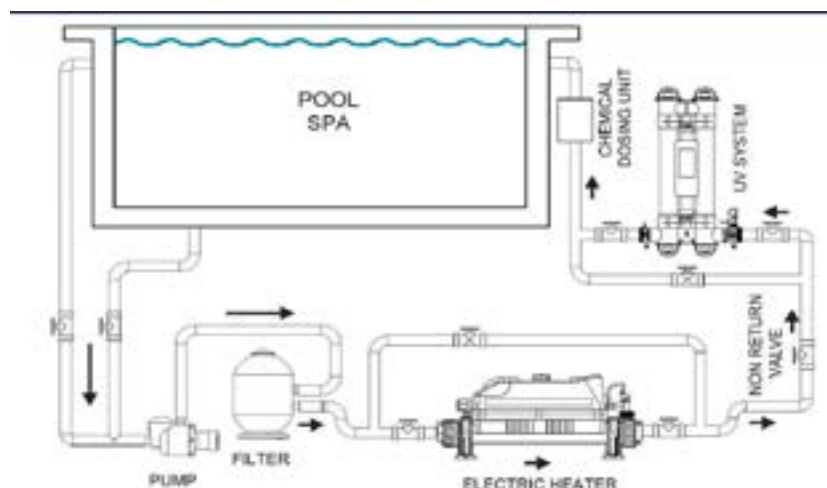



G2 MULTI TUBULAR Heat Exchangers



- FOUR MODELS AVAILABLE RANGING FROM 30-kW TO 122-kW
- TITANIUM TUBE BUNDLE
- BS 316L STAINLESS STEEL PRIMARY CASING
- 4 BAR PRESSURE TOLERANCE
- LOW PRESSURE DROP
- OPTIONAL ANALOGUE OR SMART TOUCHSCREEN CONTROLLER AND BOOSTER PUMP
- TEMPERATURE AND FLOW SENSOR PORT
- SEA AND SALT CHLORINATED WATER COMPATIBLE
- FOR HEATING OR COOLING
- FLOOR OR WALL MOUNTABLE



	30 kW (102k BTU)	49 kW (167k BTU)	85 kW (290k BTU)	122 kW (416k BTU)
PRODUCT CODE - F	G2-HE-30T	G2-HE-49T	G2-HE-85T	G2-HE-122T
PRICE GBP	£ 374	£ 462	£ 566	£ 791

TECHNICAL SPECIFICATIONS	
Flow Tube (Primary)	BS 316L stainless steel tube
Water Connections	1" BSP male fittings
Working Pressure	4 bar maximum
Flow Tube (Secondary)	Bundle of 37 titanium tubes
Water Connections	1 1/2"/50mm stepped ABS unions for rigid pipe connection
Working Pressure	4 bar maximum

PERFORMANCE												
STANDARD POWER OUTPUT	PRIMARY FLOW (m3/h)	PRIMARY PRESSURE LOSS (Bar)	SECONDARY FLOW (m3/h)	SECONDARY PRESSURE LOSS (Bar)	ΔT 15oC kW	ΔT 20oC kW	ΔT 30oC kW	ΔT 40oC kW	ΔT 50oC kW	ΔT 60oC kW	ΔT 70oC kW	
30-kW	1.1	0.061	10	0.05100	9	11	16	20	26	30	33	
30-kW	1.3	0.068	10	0.05100	10	13	18	23	31	34	39	
30-kW	1.3	0.068	14	0.18732	11	15	20	26	34	41	46	
49-kW	1.6	0.077	16	0.37254	13	18	25	43	41	50	56	
49-kW	1.8	0.083	16	0.37254	15	20	28	38	45	55	62	
49-kW	2.2	0.093	17	0.42642	16	22	33	44	52	64	73	
85-kW	2.4	0.113	17	0.52698	22	28	40	53	64	75	81	
85-kW	2.7	0.129	17	0.52698	26	32	46	60	73	82	89	
85-kW	3.2	0.147	17	0.52698	28	34	49	64	77	90	102	
122-kW	3.8	0.183	19	0.73434	33	43	68	75	93	108	120	
122-kW	4.2	0.200	19	0.72424	36	48	70	89	108	126	143	
122-kW	4.6	0.211	19	0.73434	38	53	73	95	116	137	156	



POOL SMART and HEAT SMART

- SMART TOUCHSCREEN DISPLAY
- BMS (BUILDING MANAGEMENT SYSTEM) INTEGRATION READY
- MULTI-LINGUAL INTERFACE
- PROGRAMMABLE 24-HOUR TIME CLOCK (4 TIME ZONES)
- FLOW AND TEMPERATURE SENSOR PORTS
- ACCURATE CONTROL TO 0.5°C
- DIAGNOSTIC DISPLAY
- ELEGRO APP
- FLOW SWITCH (HEATSMART 1M, POOLSMART 3M)
- TEMPERATURE SENSOR (HEATSMART 1M, POOLSMART 3M)



	Pool Smart For Electric Heaters	Heat Smart For Heat Exchangers	Analogue Thermostat For Heat Exchangers
PRODUCT CODE - F	PSPC-POOL	PSPC-HE	G2-HE-ANA
PRICE GBP	£ 403	£ 382	£ 220

TECHNICAL SPECIFICATIONS	
Power	Single Phase
Models	Heating only
Thermostat	Digital (Pool Smart and Heat Smart) Analogue (Analogue)
Ingress Rating	IP44
Frequency	50/60 Hz
Mounting	Wall Mounting

ASSOCIATED PRODUCTS



EVOLUTION 2 ELECTRIC HEATERS

Page 46



G2 HEAT EXCHANGERS

Page 47

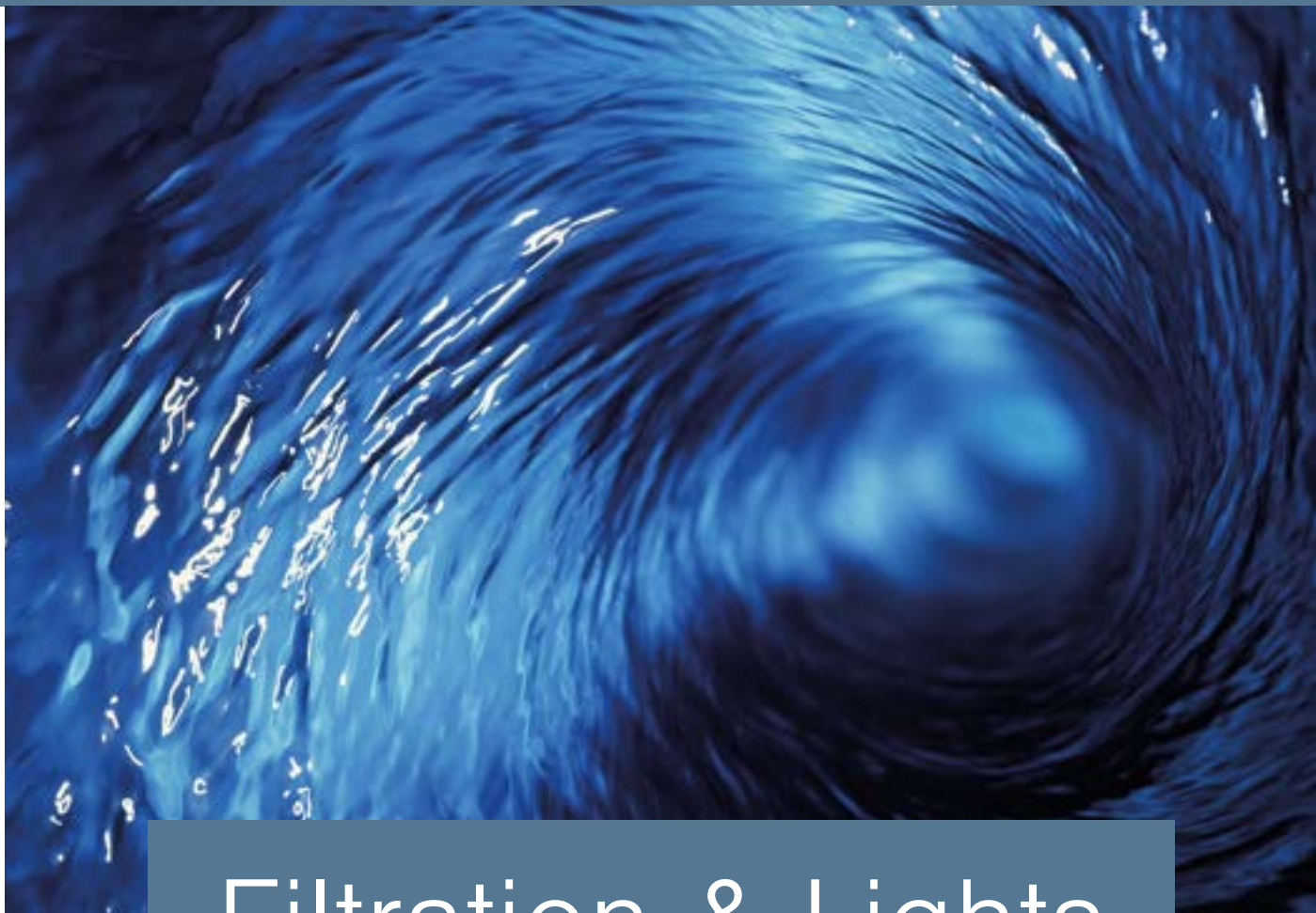

Filtration & Lights

INTRODUCTION	p.49	MEDIA	p.71
PUMPS	p.51	• Bayrol AFM	p.71
• HF Alphaflo	p.52	• Bayrol Glass and Sand	p.72
• HF Alphaflo VS	p.54	• Pump and Filter	p.73
• Hydrostar Mk 4	p.56	Combinations	
• Hydrostar Plus	P.58	LIGHTS	p.74
FILTERS	p.60	• Mini Brio 2	p.74
• Micron Side Mounted	p.62	• MID Brio	p.76
• Micron Top Mounted	p.64	• Brio WiL Controller	p.78
• Exotuf Top Mounted	p.66		
• SMD Commercial	p.68		
• SMD Deep Bed	p.69		
Commercial			
• Multi Cyclone	p.70		



HEATFORM AND WATERCO FILTRATION, A COMPLETE RANGE DESIGNED FOR YOU

HeatForm is expanding its pool equipment solution by offering a complete range of pumps and filters.

Utilising Waterco's expertise, proven on the American and Australian markets, this range has been designed with your needs in mind, to help you deliver 100% customer satisfaction.

> A SOLUTION ADAPTED TO EVERY NEED



HF AlphaFlo ECO V
Variable speed pumps

3 speed ECO V system for maximum energy efficiency

HF Alphaflo
Single-speed pump

A range of long-lasting and efficient pumps



WATERCO Hydrostar
Commercial Pumps



MULTICYCLONE

Waterco's award-winning MultiCyclone technology uses the most advanced hydro-cyclone technology to ensure high water quality and clarity



MICRON
Bobbin wound filters

A range of efficient and long-lasting premium media filters

WATERCO
Commercial Filters



BAYROL AFM

AFM from BAYROL is the best filtration media available today. AFM combines perfectly with the Waterco filtration systems.



BAYROL ECO FILTERGLASS

Eco Filter glass from BAYROL is available in 2 different grades and is the perfect alternative to sand.

> SINGLE AND VARIABLE SPEED PUMPS, LONG-LASTING AND EFFICIENT FOR ALL POOLS

HF Alphaflo pumps are designed with corrosion-resistant materials. The body of the pump is made of very thick polypropylene, **making it long-lasting and quiet when operating.**

Equipped with highly energy-efficient synchronous motors, the range is available in 8 models (from 0.5 to 2.0 HP, available in single or three phase (except for the 0.5 and 0.75HP models), **to meet the needs of most pools.**

3 YEAR
WARRANTY

ALL TYPES OF
SWIMMING
POOLS

LARGE
CAPACITY

EASY
MAINTENANCE

EASY
RETROFIT

STANDARD INSTALLATION

- 1 HF Alphaflo pump
- 2 Micron filter
- 3 Heating system
- 4 Water treatment system

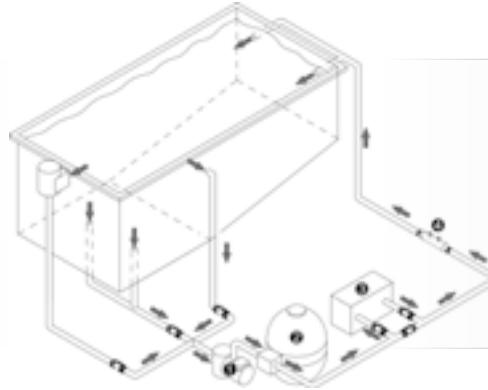

COMPARATIVE TABLE OF THE RANGE

	HF Alphaflo Eco V 100	HF Alphaflo Eco V 150	HF Alphaflo	Hydrostar
	Variable-speed pump, for maximum energy efficiency		Single-speed pumps, long-lasting and efficient for all pools	Commercial Pumps from Waterco
Warranty	3 years	3 years	3 years	2 years
"Easy retrofit" installation	•	•	•	
High capacity pre-filter	•	•	•	
Number of speeds	8	10	1	1
Pump speed	1000-2850 RPM	1000-2850 RPM	2880 RPM	2940 RPM
Number of models	1	1	9	7
Power (P2)	1.00 HP	1.50 HP	0.5 to 2.0 HP	4.0 to 15.0 HP
Max. pool volume	Up to 120 m ³	Up to 165 m ³	Up to 150 m ³	
Optimum efficiency	30-80 m ³		Model Specific	Model Specific



HF Alphaflo - Single speed

- + Built to last
- + High efficiency
- + Silent operation

3 YEAR
WARRANTY



	Alphaflo 050	Alphaflo 075	Alphaflo 100	Alphaflo 150	Alphaflo 200	Alphaflo 100 - 3ph	Alphaflo 150 - 3ph	Alphaflo 200 - 3ph
--	--------------	--------------	--------------	--------------	--------------	--------------------	--------------------	--------------------

PRODUCT CODE - B

Standard model	248050EUM	248075EUM	248100EUM	248150EUM	248200EUM	248100-3EUM	248150-3EUM	248200-3EUM
	£ 770	£ 805	£ 840	£ 925	£ 940	£ 840	£ 925	£ 940

ACCESSORIES INCLUDED IN THE PACK



2" union tailpieces

DESCRIPTION

Operating mode(s)	Controlled by the filtration timer
Nominal speed	2850 RPM
Safety features	Automatic shutdown in case of high amperage / overheat situation
Filter basket volume	2 L
Compatible pipework	2" inlet & outlet union tailpieces provided
Use	Fresh water and salt water up to 6 g/L (6000 ppm)

TECHNICAL SPECIFICATIONS

Pump type	Self-priming water pump				
Motor type	Asynchronous motor, TEFC, class F insulation				
Efficiency	> 80 % (as per IE3 standard)				
Output power HP (P2)	0.5	0.75	1	1.5	2
Input power Kw (P2)	0.53	0.73	1.0	1.61	2
Max amperage (A)	2.4	3.3	4.7	6.9	9.0
Power supply	Single phase				
Flow rate at 10m head (m³/h)	6 m³/h	9 m³/h	15 m³/h	23 m³/h	29 m³/h
Maximum flow rate (m³/h)	15 m³/h	17 m³/h	23 m³/h	30 m³/h	35m³/h
Maximum water temperature	40 °C				
Protection rating	IPX5				

PERFORMANCE - HF ALPHAFLO SINGLE SPEED

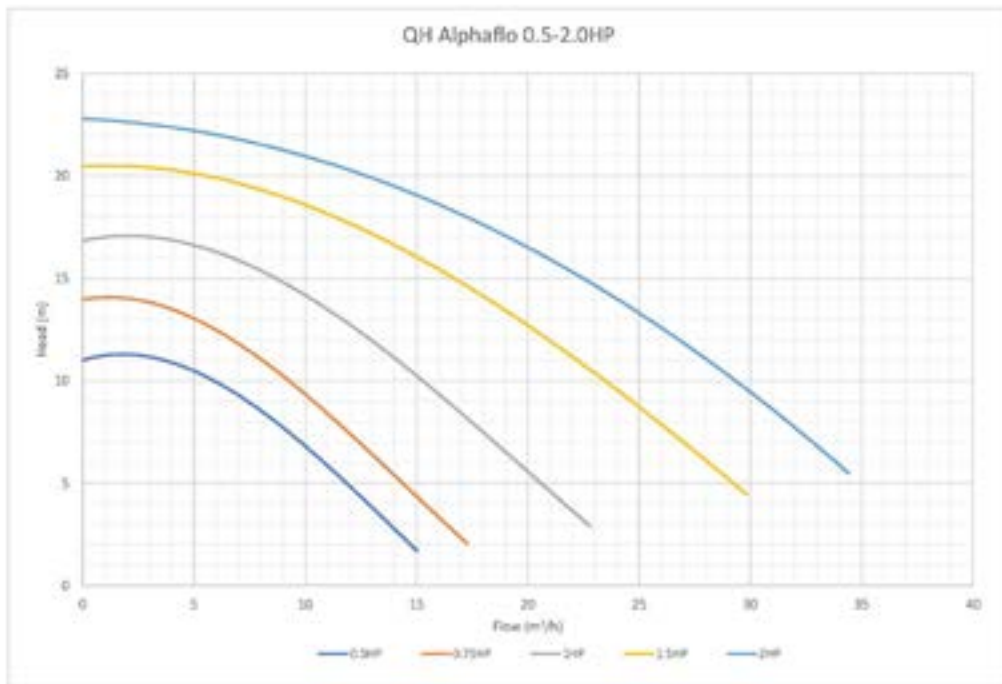

DIMENSIONS - HF ALPHAFLO PUMPS

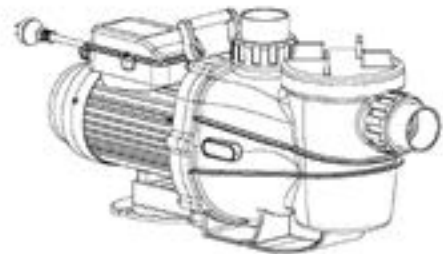
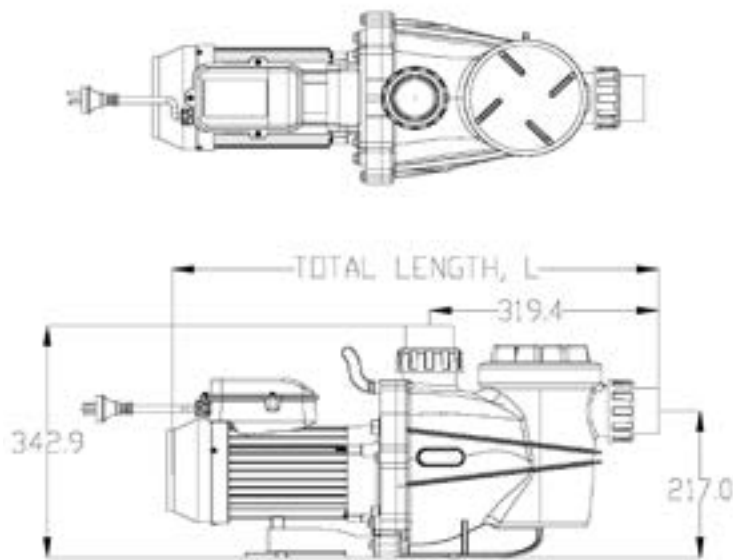

Pump PN	HP	TOTAL LENGTH, L (mm)
248050EUM	0.50HP	626
248075EUM	0.75HP	626
248100EUM	1.00HP	626
248150EUM	1.50HP	645
248200EUM	2.00HP	685
2481009EUM	ECO-V100	657
2481509EUM	ECO-V150	657



HF Alphaflo - Variable Speed

- + 3 Speeds
- + Built to last
- + High efficiency
- + Silent operation



3 YEAR
WARRANTY

Alphaflo Eco-V 100

Alphaflo Eco-V 150

PRODUCT CODE - B

Standard model	2481009EUM	2481509EUM
	£ 1,700	£ 1,900

ACCESSORIES INCLUDED IN THE PACK



2" union tailpieces

DESCRIPTION

Operating mode(s)	Controlled by ECO-V Controller	
Nominal speed	1000 - 2850 RPM	
Safety features	Automatic shutdown in case of high amperage / overheat situation	
Filter basket volume	2 L	
Compatible pipework	2" inlet & outlet union tailpieces provided	
Use	Fresh water and salt water up to 6 g/L (6000 ppm)	

TECHNICAL SPECIFICATIONS

Pump type	Self-priming water pump	
Motor type	Asynchronous motor, TEFC, class F insulation	
Efficiency	> 80 % (as per IE3 standard)	
Output power HP (P2)	1.0	1.5
Input power Kw (P2)	0.91	1.416
Max amperage (A)	6.1	9.0
Power supply	Single phase	
Maximum flow rate (m³/h)	20.1 m³/h	27.7m³/h
Maximum water temperature	40 °C	
Protection rating	IPX5	

PERFORMANCE - HF ALPHAFLO VARIABLE SPEED

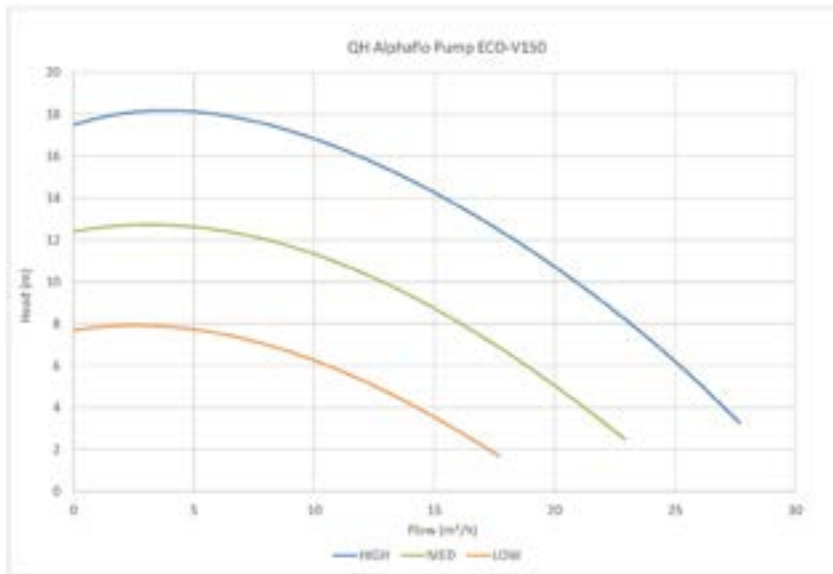
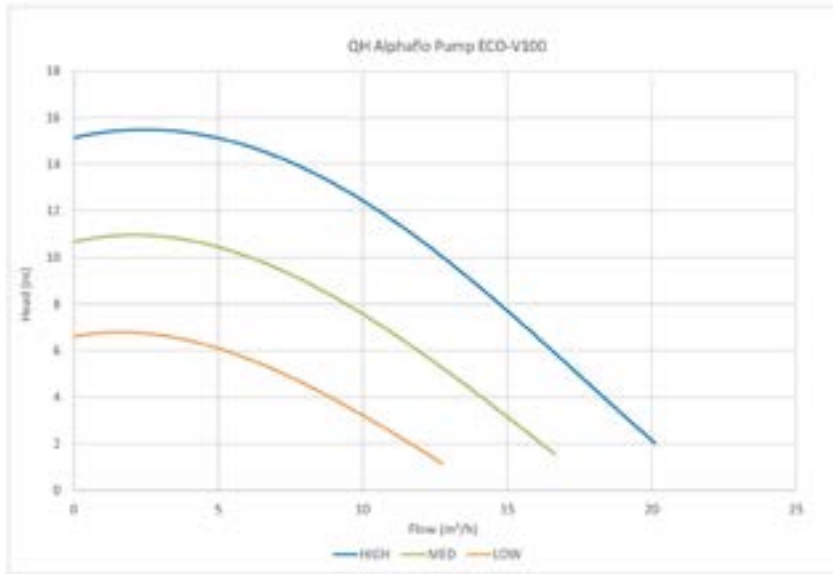

DIMENSIONS - HF ALPHAFLO PUMPS

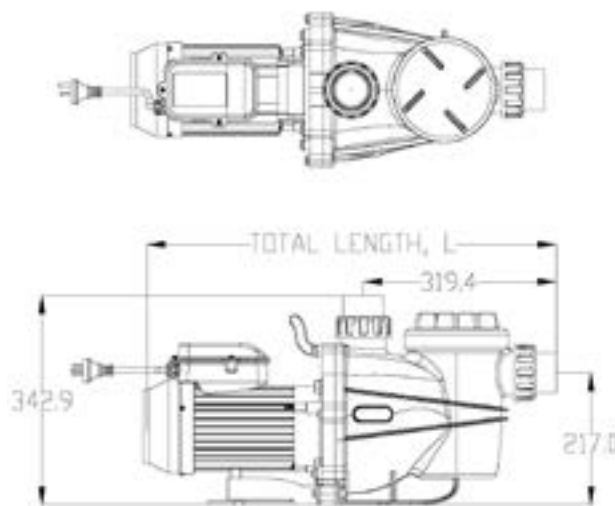

Pump PN	HP	TOTAL LENGTH, L (mm)
248050EUM	0.50HP	626
248075EUM	0.75HP	626
248100EUM	1.00HP	626
248150EUM	1.50HP	645
248200EUM	2.00HP	685
2481009EUM	ECO-V100	657
2481509EUM	ECO-V150	657



Waterco Hydrostar Mk 4

- + Built to last
- + High efficiency
- + Silent operation



Hydrostar 400MKIV

Hydrostar 550MKIV

Hydrostar 700MKIV

PRODUCT CODE - E

Standard model	240440033EUM	240455033EUM	240470033EUM
	£ 1,449	£ 1,724	£ 1,949

ACCESSORIES INCLUDED IN THE PACK



3" union tailpieces

DESCRIPTION

Operating mode(s)	Controlled by the filtration timer
Nominal speed	2900 RPM
Compatible pipework	3" inlet & outlet union tailpieces provided

TECHNICAL SPECIFICATIONS

Pump type	Self-priming water pump		
Motor type	Asynchronous motor, TEFC, class F insulation		
Efficiency	> 80 % (as per IE3 standard)		
Output power HP (P2)	4.0	5.7	7.2
Input power Kw (P2)	2.98	3.16	5.18
Max amperage (A)	5.2	8.1	10.3
Power supply	Three Phase - 380-415V		
Maximum water temperature	40 °C		
Protection rating	IPX5		

PERFORMANCE - HYDROSTAR MK4

Flow Curve
Hydrostar 400 Mk4

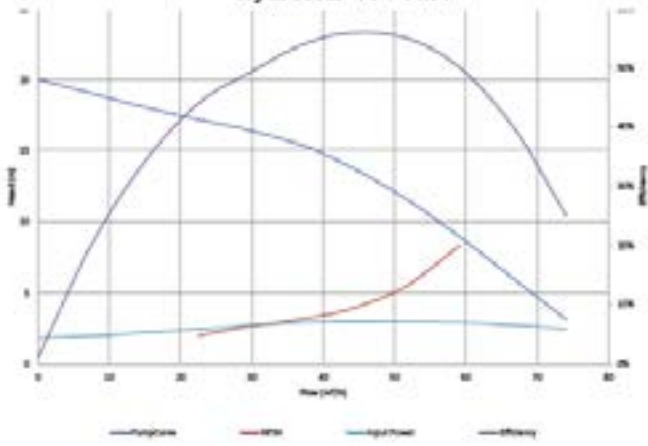

Hydrostar 550 Mk4

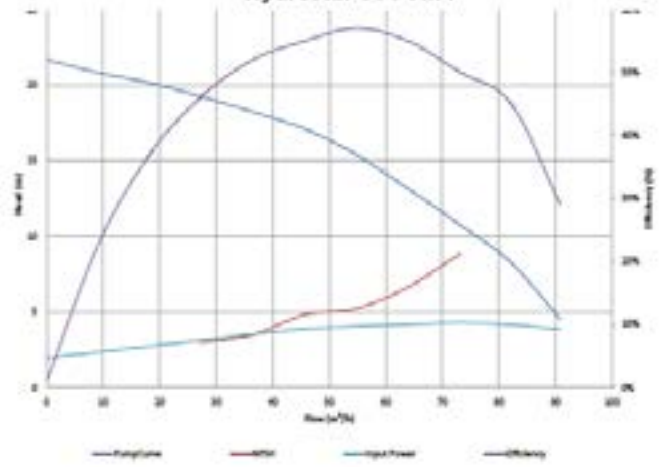

Hydrostar 700 Mk4

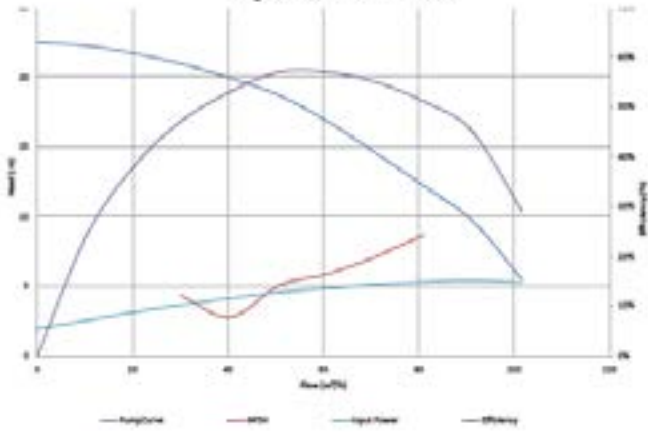

Noise Level

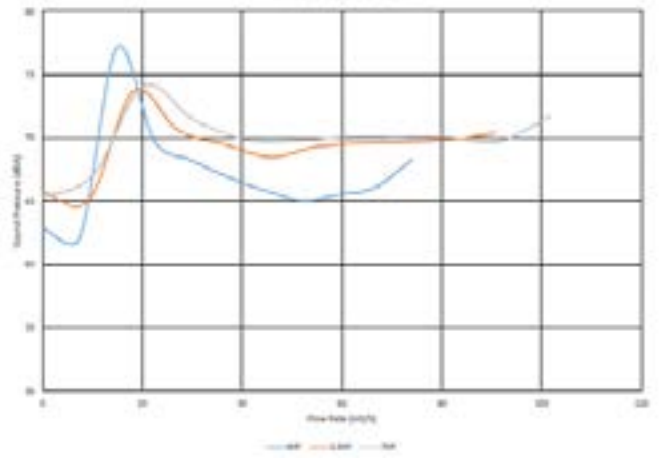

DIMENSIONS - HYDROSTAR MK4

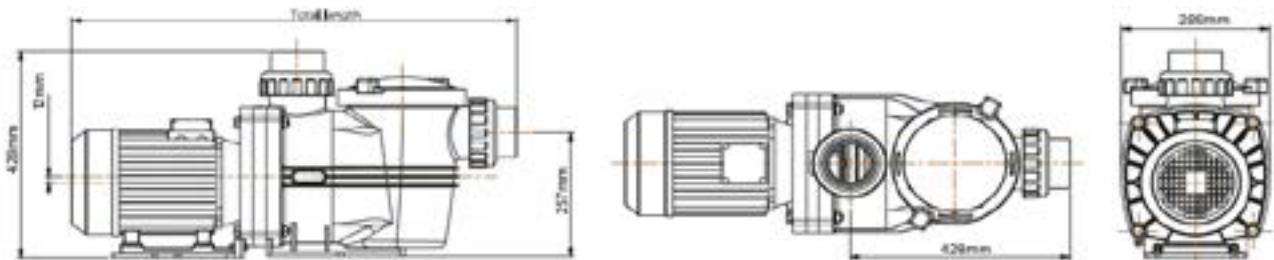



Waterco Hydrostar Plus

- + Built to last
- + High efficiency
- + Silent operation



	Hydrostar Plus 7.5HP	Hydrostar Plus 10HP	Hydrostar Plus 12.5HP	Hydrostar Plus 15HP
--	-------------------------	------------------------	--------------------------	------------------------

PRODUCT CODE - E

Standard model	2460750EUM	2461000EUM	2461250EUM	2461500EUM
	£ 3,231	£ 3,683	£ 4,074	£4,422

DESCRIPTION

Operating mode(s)	Controlled by the filtration timer
Nominal speed	2900 RPM
Compatible pipework	3" inlet & outlet union tailpieces provided

TECHNICAL SPECIFICATIONS

Pump type	Self-priming water pump			
Motor type	Asynchronous motor, TEFC, class F insulation			
Efficiency	> 80 % (as per IE3 standard)			
Output power HP (P2)	8.3	11.4	14.1	15.3
Input power Kw (P2)	6.2	8.5	10.5	11.4
Max amperage (A)	10.15	14.35	17.6	20.3
Power supply	Three Phase - 380-415V			
Maximum water temperature	40 °C			
Protection rating	IPX5			

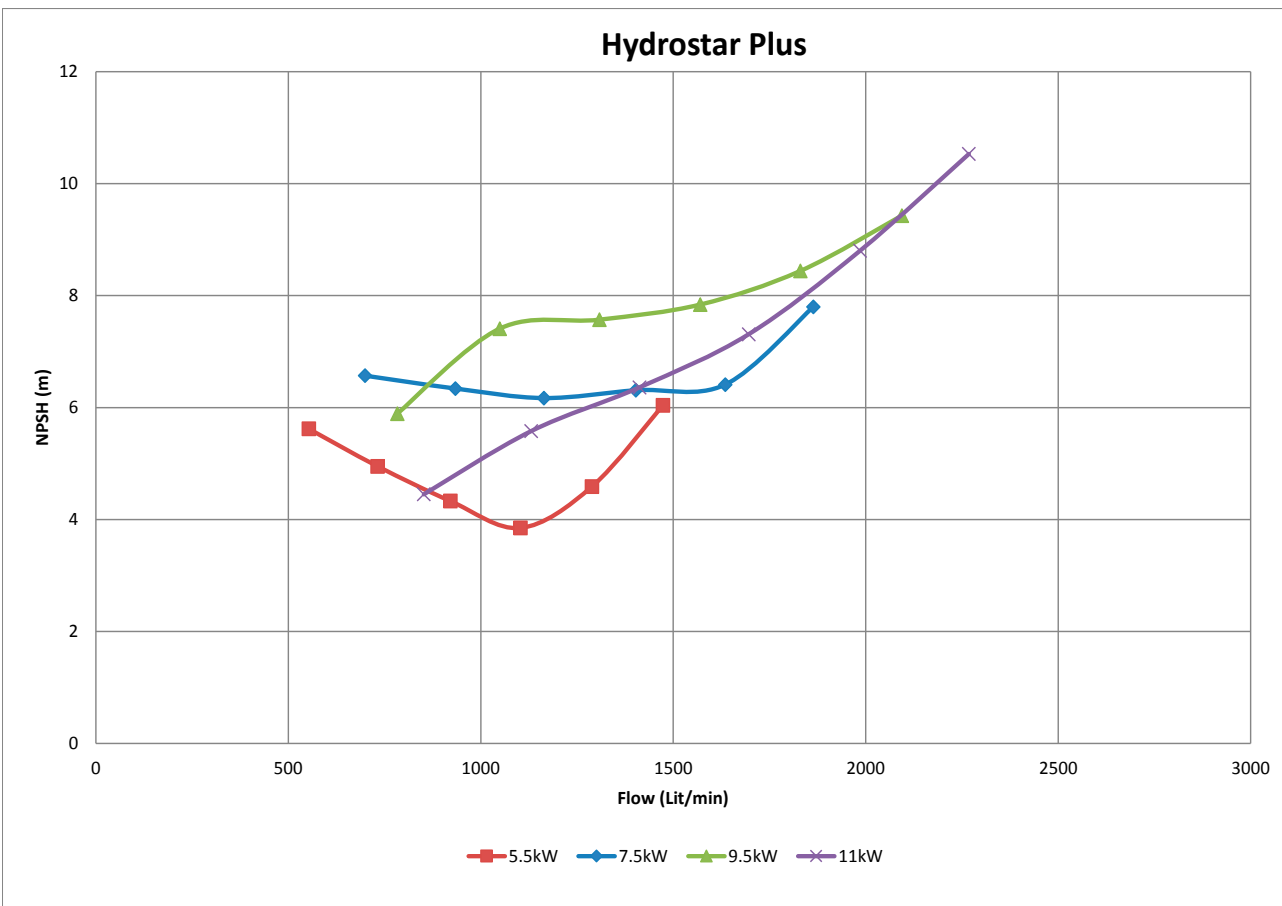
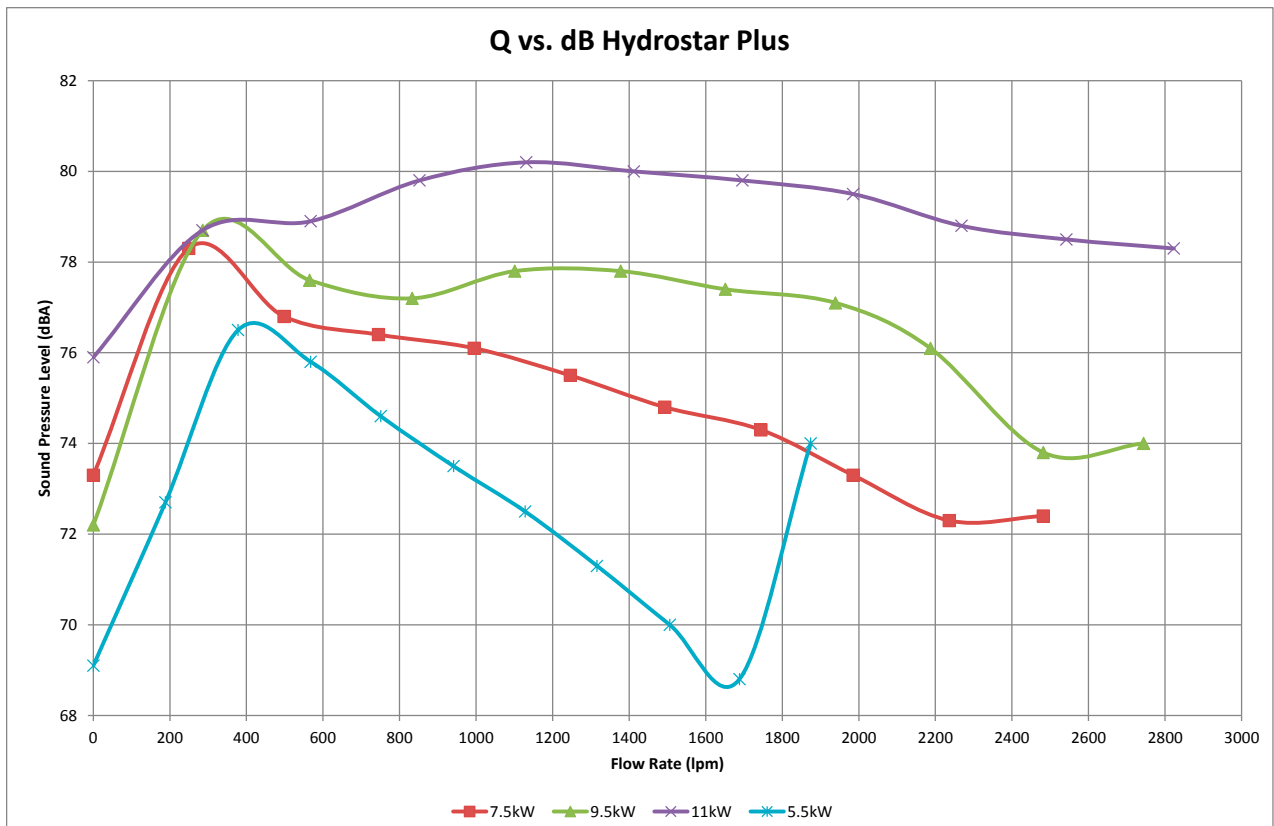



Micron - Side Mounted Sand filters

- + Easy to install
- + Efficient filtration
- + Easy maintenance



10 YEAR
WARRANTY

	Micron SM 500	Micron SM 600	Micron SM 700	Micron SM 750	Micron SM 900
--	---------------	---------------	---------------	---------------	---------------

PRODUCT CODE - C					
Standard model	22000820EU	22000824EU	22000828EU	22000830EU	22000836EU
	£ 883	£ 941	£ 1,129	£ 1,471	£ 1,937

ACCESSORIES INCLUDED IN THE PACK

		
Multiport valve kit	Pressure gauge & air relief kit	Media filling cap

DESCRIPTION

Tank material	Bobbin wound
Multiport valve	6-way side mount valve (filtration, backwash, rinse, drain, circulation, closed)
Pressure gauge position	Onto the top cover using a T-shape adaptor threaded into the lid
Connections	All connections are threaded for easy maintenance (multiport valve & piping)
Drain	3/8" (water) / 2 1/2" (filter media)

TECHNICAL SPECIFICATION

Model	Inner Diam (mm)	Bed Depth (mm)	Filter Area (m ²)	Valve Size (in/mm)	Sand 16/30 (kg)	BAYROL Glass (kg)	BAYROL AFM (kg)	Dom. flow (m ³ /hr)	Max Pool Size (m ³)	Com. flow (m ³ /hr)	Min pool Size (m ³)
SM500	500	290	0.20	1.5/50	95	78	105	9.4	56	7.1	43.2
SM600	600	360	0.28	1.5/50	165	136	183	13.6	81	10.2	60.5
SM700	700	380	0.38	2/63	197	197	265	18.5	111	13.9	82.1
SM750	750	400	0.44	2/63	234	234	315	21.2	127	15.9	95.0
SM900	900	440	0.64	2/63	440	362	487	30.5	183	22.9	138.2

DIMENSIONS MM

Model	A	B	C	W	R	P	E	F	K	H	L	X	Y	Z	J	S	T	V
SM500	475	520	846	306	249	153	594	649	100	585	70	743	790	715	445	485	282	652
SM600	526	622	906	306	249	153	629	684	105	601	88	804	825	778	540	520	317	690
SM700	587	719	981	334	262	178	520	601	120	685	90	905	750	835	620	520	317	728
SM750	613	772	976	334	262	178	593	674	113	652	120	914	823	892	678	593	390	763
SM900	689	923	1086	334	262	178	656	737	113	750	120	1030	886	1011	678	656	453	860

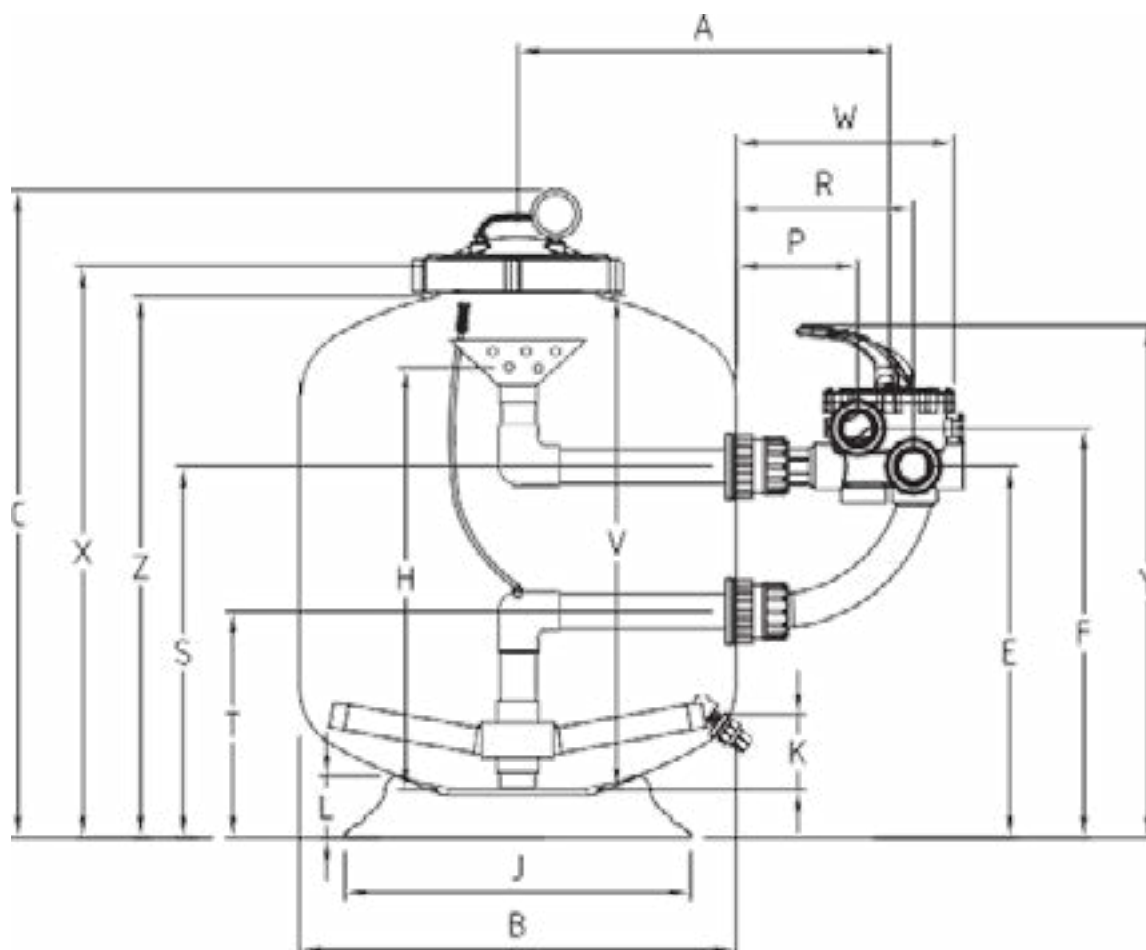

ASSOCIATED PRODUCTS

			
BAYROL AFM	BAYROL ECO FILTERGLASS	WATERCO ECOPURE	FILTER SAND AND GRAVEL
Page 71	Page 72	Page 73	Page 73
£ 41.00	£ 29.00	£18.94	£16.98





Micron - Top Mounted Sand filters

- + Easy to install
- + Efficient filtration
- + Easy maintenance



10 YEAR
WARRANTY

	Micron 500	Micron 600	Micron 700	Micron 750	Micron 900
PRODUCT CODE - C					
Standard model	220122DP	220124DP	220128DP	220130DP	220136DP
	£ 667	£ 795	£ 940	£ 1,310	£ 1,581

ACCESSORIES INCLUDED IN THE PACK		
		
Multiport valve kit	Pressure gauge & air relief kit	Media filling cap

DESCRIPTION	
Tank material	Bobbin wound
Multiport valve	6-way top mount valve (filtration, backwash, rinse, drain, circulation, closed)
Pressure gauge position	Onto the top cover using a T-shape adaptor threaded into the lid
Connections	All connections are threaded for easy maintenance (multiport valve & piping)
Drain	3/8" (water) / 2 1/2" (filter media)



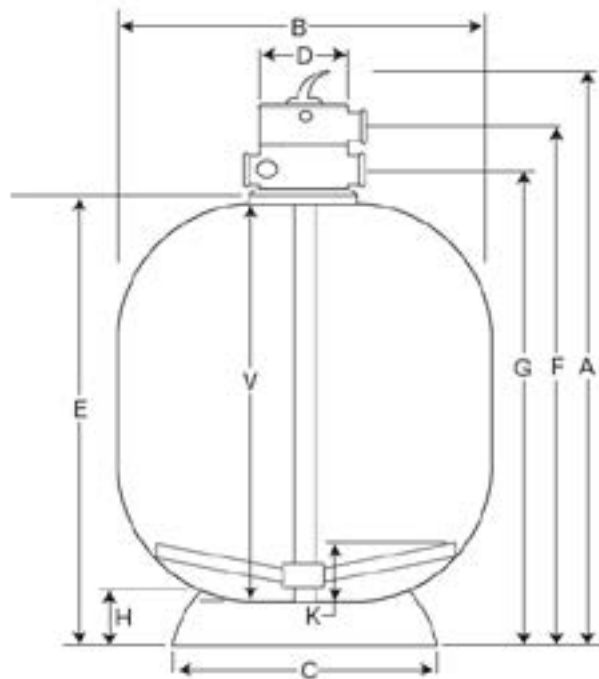

TECHNICAL SPECIFICATION											
Model	Inner Dia (mm)	Bed Depth (mm)	Filter Area (m ²)	Valve Size (in/mm)	Sand 16/30 (kg)	BAYROL Glass (kg)	BAYROL AFM (kg)	Dom. flow (m ³ /hr)	Max Pool Size (m ³)	Com. flow (m ³ /hr)	Min pool Size (m ³)
S500	500	280	0.20	1.5/50	95	78	105	9.4	57	7.1	28
S600	600	295	0.28	1.5/50	155	127	171	13.6	83	10.2	41
S700	700	330	0.38	1.5/50	230	189	254	18.5	115	13.9	56
S750	750	340	0.44	2/63	260	214	288	21.2	132	15.9	64
S900	900	420	0.64	2/63	470	386	520	30.5	183	22.9	92

DIMENSIONS MM

Model	A	B	C	W	R	P	E	F	K	H	L	X	Y	Z	J	S	T	V
S500	864	505	484	180	625	731	672	88	525	94	70	743	790	715	445	485	282	652
S600	968	622	484	180	721	832	778	88	620	136	88	804	825	778	540	520	317	690
S700	932	723	620	180	692	801	743	90	650	139	90	905	750	835	620	520	317	728
S750	1217	772	620	220	867	1037	937	90	773	127	120	914	823	892	678	593	390	763
S900	1234	910	620	220	884	1054	954	90	785	163	120	1030	886	1011	678	656	453	860



ASSOCIATED PRODUCTS

			
BAYROL AFM	BAYROL ECO FILTERGLASS	WATERCO ECOPURE	FILTER SAND AND GRAVEL
Page 71	Page 72	Page 73	Page 73
£ 41.00	£ 29.00	£18.94	£16.98





EXOTUF - Top Mounted Sand filters

- + Easy to install
- + Efficient filtration
- + Easy maintenance



	Exotuf 400	Exotuf 450	Exotuf 500	Exotuf 600
PRODUCT CODE - C				
Standard model	2260166DP	2260186DP	2260206DP	2260246DP
	£ 393	£ 436	£ 530	£ 658

ACCESSORIES INCLUDED IN THE PACK

		
multiport valve kit	Pressure gauge & air relief kit	Media filling cap

DESCRIPTION

Tank material	Injection moulded plastic
Multiport valve	6-way top mount valve (filtration, backwash, rinse, drain, circulation, closed)
Pressure gauge position	Onto the top cover using a T-shape adaptor threaded into the lid
Connections	All connections are threaded for easy maintenance (multiport valve & piping)
Drain	3/8" (water) / 2 1/2" (filter media)

TECHNICAL SPECIFICATION

Model	Inner Dia (mm)	Bed Depth (mm)	Filter Area (m ²)	Valve Size (in/mm)	Sand 16/30 (kg)	BAYROL Glass (kg)	BAYROL AFM (kg)	Max flow (m ³ /hr)	Max Pool Size (m ³)
E400	400	160	0.13	1.5/50	40	30	44	6	36
E450	450	250	0.16	1.5/50	75	75	60	7	45
E500	500	250	0.2	1.5/50	90	70	100	8	57
E600	600	250	0.28	1.5/50	130	105	140	14	81

DIMENSIONS MM

Model	A	B	C	D	E	F	G	H	V	K
E400	775	460	280	180	530	642	584	34	481	89
E450	840	504	280	180	595	707	649	30	530	112
E500	905	550	484	182	618	762	671	88	522	108
E600	942	650	484	182	655	799	708	88	546	115

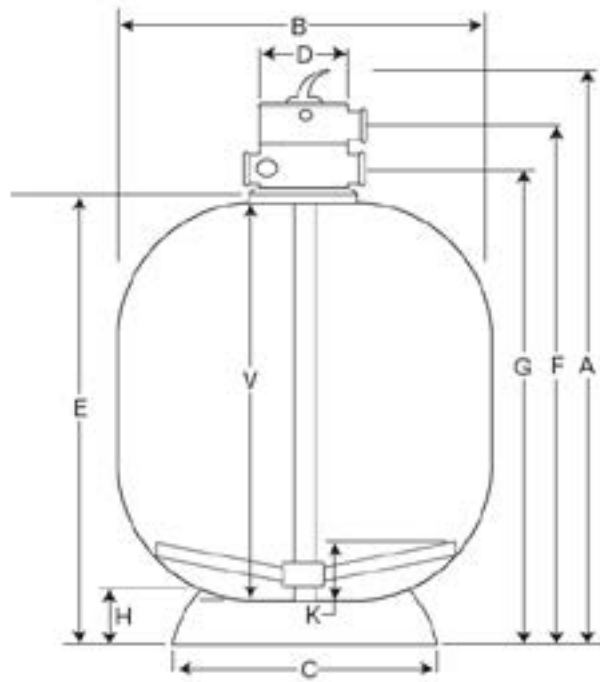

ASSOCIATED PRODUCTS

			
BAYROL AFM	BAYROL ECO FILTERGLASS	WATERCO ECOPURE	FILTER SAND AND GRAVEL
Page 71	Page 72	Page 73	Page 73
£ 41.00	£ 29.00	£18.94	£16.98



WATERCO SMD - Side Mounted Commercial Sand filters

- + Large double yoke lid
- + Pressure Gauge
- + Large clear sight glass
- + Quick connect unions
- + Water purge and sand dump port
- + Large stable base
- + Fishtail lateral configuration



10 YEAR
WARRANTY



SMD 600	SMD 750	SMD 900	SMD 1050	SMD 1200	SMD 1400	SMD 1600	SMD 1600 4»	SMD 1800	SMD 2000
---------	---------	---------	----------	----------	----------	----------	-------------	----------	----------

PRODUCT CODE - E

Standard model	SMD600	SMD750	SMD900	SMD1050	SMD1200	SMD1400	SMD1600	SMD1600/4	SMD1800	SMD2000
	£1,357	£1,521	£3,649	£4,090	£4,856	£6,009	£7,503	£7,861	£9,826	£11,915

DESCRIPTION

Tank material	Bobbin wound Commercial Filter
Multiport valve	6-way side mount valve (filtration, backwash, rinse, drain, circulation, closed)
Pressure gauge position	Onto the top cover using a T-shape adaptor threaded into the lid
Connections	All connections are threaded for easy maintenance (multiport valve & piping)
Drain	3/8" (water) / 2 1/2" (filter media)

TECHNICAL SPECIFICATION

Model	Con size (in/mm)	Bed Depth (mm)	Filter Area (m ²)	Max Flow Rating 30m ³ /hr/m ²	Max Flow Rating 40m ³ /hr/m ²	Sand (kg)	BAYROL Glass (kg)	BAYROL AFM (m ³ /hr)
SMD600	1.5/50	1000	0.28	8.5	11.3	445	490	356
SMD750	2.0/63	1000	0.44	13	18	670	570	540
SMD900	3.0/90	1000	0.64	19	25	1060	1016	850
SMD1050	3.0/90	1000	0.87	26	35	1410	1159	1130
SMD1200	3.0/90	1000	1.13	34	45	1720	1414	1380
SMD1400	3.0/90	1000	1.54	46	62	2515	2067	2020
SMD1600	3.0/90	1000	2.01	60	80	3170	2605	2540
SMD1600/4	4.0/110	1000	2.01	60	80	3060	2515	2450
SMD1800	4.0/110	1000	2.54	76	102	4205	3456	3370
SMD2000	4.0/110	1000	3.14	94	126	5140	4225	4120

ASSOCIATED PRODUCTS

2.5"/75MM SIDE MOUNT MPV	2.5"/75MM SIDE MOUNT MPV WITH PLUMBING KIT	3"/90MM SIDE MOUNT MPV	3"/90MM SIDE MOUNT MPV WITH PLUMBING KIT	4"/110MM SIDE MOUNT MPV	4"/110MM SIDE MOUNT MPV WITH PLUMBING KIT
2290504	22905040	2290900	22909005	2291100	2291105
£ 374.63	£ 483.96	£ 711.34	£ 914.30	£ 1,436.05	£ 1614.84

DIMENSIONS MM

Model	A	B	C	W	R	P	E	F	K	V	H	L	X	Y	Z	J	S	T
SMD600	619	622	1630	334	262	191	977	1234	-	-	-	-	-	-	-	-	-	-
SMD750	613	772	1660	334	262	191	1226	1328	113	1420	1363	120	1585	1482	1560	678	1226	1023
SMD900	824	923	1918	510	363	548	1406	1516	190	1580	1440	155	1833	1788	1763	735	1406	1050
SMD1050	918	1110	1930	510	363	548	1100	1210	220	1605	1470	176	1845	1482	1775	1045	1100	744
SMD1200	977	1229	1935	510	363	548	1154	1264	150	1590	1400	176	1850	1536	1780	1045	1154	798
SMD1400	1083	1442	1955	510	363	548	1204	1314	250	1615	1500	218	1870	1586	1800	1202	1204	848
SMD1600	1184	1644	1994	510	363	548	1151	1261	220	1615	1500	218	1909	1533	1839	1202	1151	795
SMD1600/4	1765	1644	1994	943	474	629	757	419	180	1615	1430	218	1909	757	1839	1202	1189	757
SMD1800	1863	1839	1985	943	474	629	751	413	225	1710	1475	315	1900	751	1830	1755	1183	751
SMD2000	1964	2042	2063	943	474	629	758	420	300	1765	1550	245	1978	758	1908	1755	1190	758

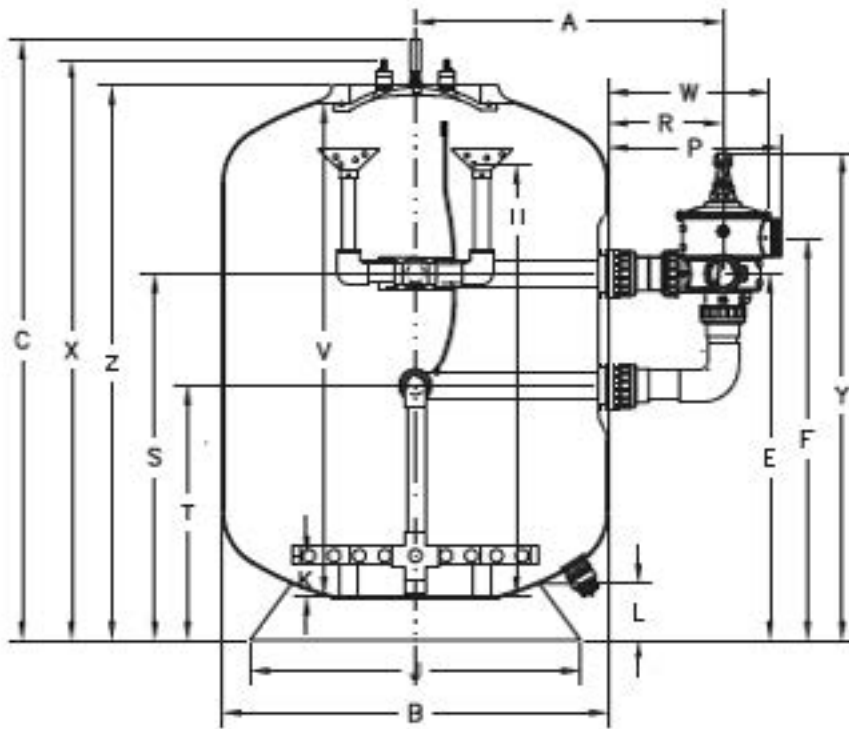

ASSOCIATED PRODUCTS

			
BAYROL AFM	BAYROL ECO FILTERGLASS	WATERCO ECOPURE	FILTER SAND AND GRAVEL
Page 71	Page 72	Page 73	Page 73
£ 41.00	£ 29.00	£18.94	£16.98



SMD Deep Bed - Side Mounted Sand filters

- + Large double yoke lid
- + Pressure Gauge
- + Large clear sight glass
- + Quick connect unions
- + Water purge and sand dump port
- + Large stable base
- + Fishtail lateral configuration



10 YEAR
WARRANTY



SMDD 750	SMDD 900	SMDD 1050	SMDD 1200	SMDD 1400	SMDD 1600	SMDD 1800	SMDD 2000	SMDD 2200	SMDD 2350	SMDD 2500
----------	----------	-----------	-----------	-----------	-----------	-----------	-----------	-----------	-----------	-----------

PRODUCT CODE - E

Standard model	SMDD750	SMDD900	SMDD1050	SMDD1200	SMDD1400	SMDD1600	SMDD1800	SMDD2000	SMDD2200	SMDD2350	SMDD2500
	£2,501	£4,164	£5,100	£6,176	£7,497	£9,819	£12,227	£14,795	£17,931	£25,482	POA

DESCRIPTION

Tank material	Bobbin wound Deep Bed Commercial Filter
Multiport valve	6-way side mount valve (filtration, backwash, rinse, drain, circulation, closed)
Pressure gauge position	Onto the top cover using a T-shape adaptor threaded into the lid
Connections	All connections are threaded for easy maintenance (multiport valve & piping)

TECHNICAL SPECIFICATION

Model	Flange size (in/mm)	Bed Depth (mm)	Filter Area (m ²)	Max Flow Rating 30m ³ /hr/m ²	Max Flow Rating 40m ³ /hr/m ²	Sand (kg)	BAYROL Glass (kg)	BAYROL AFM (m ³ /hr)
SMDD750	2.0/63	1200	0.44	13	18	795	630	640
SMDD900	3.0/90	1200	0.64	19	25	1200	986	960
SMDD1050	3.0/90	1200	0.87	26	35	1665	1386	1340
SMDD1200	3.0/90	1200	1.13	34	45	2045	1681	1640
SMDD1400	4.0/110	1200	1.54	46	62	2840	2334	2300
SMDD1600	4.0/110	1200	2.01	60	80	3685	3029	3000
SMDD1800	6.0/160	1200	2.54	76	102	4975	4089	3980
SMDD2000	6.0/160	1200	3.14	94	126	6090	5005	4872
SMDD2200	6.0/160	1200	3.80	114	152	7625	5550	6100
SMDD2530	6.0/160	1200	4.34	130	173	8480	6970	6785
SMDD2500	6.0/160	1200	4.91	147	196	9545	7310	7640

ASSOCIATED PRODUCTS

2.5"/75MM SIDE MOUNT MPV	2.5"/75MM SIDE MOUNT MPV WITH PLUMBING KIT	3"/90MM SIDE MOUNT MPV	3"/90MM SIDE MOUNT MPV WITH PLUMBING KIT	4"/110MM SIDE MOUNT MPV	4"/110MM SIDE MOUNT MPV WITH PLUMBING KIT
2290504	22905040	2290900	22909005	2291100	2291105
£ 374.63	£ 483.96	£ 711.34	£ 914.30	£ 1,436.05	£ 1614.84

DIMENSIONS MM

Model	A	B	C	K	V	H	L	X	Z	J	S	T
SMDD750	613	772	2044	113	1780	1713	120	2011	1938	678	1586	1383
SMDD900	719	923	2268	223	1930	1823	155	2183	2113	735	1624	1324
SMDD1050	901	1077	2270	220	1950	1820	176	2185	2115	1045	1650	1294
SMDD1200	977	1229	2243	150	1900	1750	176	2158	2088	1045	1665	1309
SMDD1400	1664	1442	2313	200	1975	1800	218	2228	2158	1202	1330	898
SMDD1600	1765	1644	2285	200	1950	1800	218	2200	2130	1202	1421	989
SMDD1800	n/a	1839	2260	320	2010	1920	315	2175	2105	1755	1383	900
SMDD2000	n/a	2042	2398	320	2100	1920	245	2313	2243	1755	1310	827
SMDD2200	n/a	2245	2415	380	2090	1980	245	2330	2260	1755	1386	903
SMDD2350	n/a	2390	2435	355	2118	1955	340	2330	2330	2037	1550	1017
SMDD2500	n/a	2575	2510	335	2190	1955	340	2405	2405	2037	1494	1011

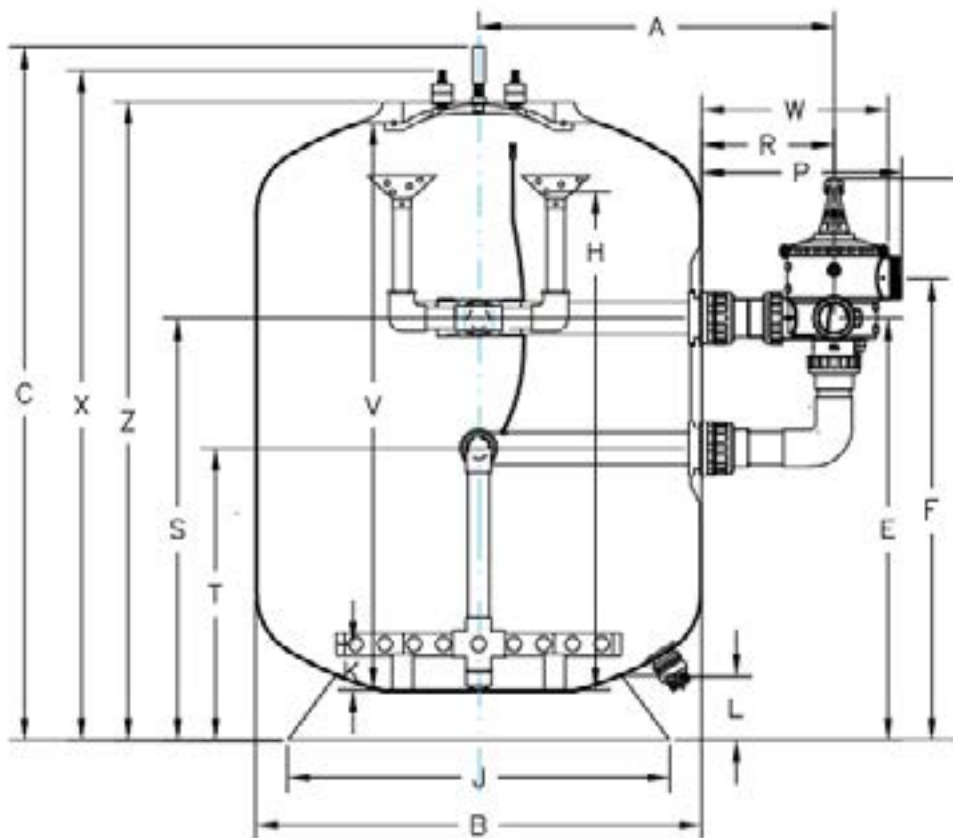

ASSOCIATED PRODUCTS



BAYROL AFM

Page 71

£ 41.00



BAYROL ECO FILTERGLASS

Page 72

£ 29.00



WATERCO ECOPURE

Page 73

£18.94



FILTER SAND AND GRAVEL

Page 73

£16.98



Multi Cyclone

- + Easy to install
- + Efficient filtration
- + Easy maintenance



	MC 12	MC 16
PRODUCT CODE - C		
Standard model	200374	200375
	£ 330	£ 425



TECHNICAL SPECIFICATIONS

Model	Hydro-cyclones	Connection Ports	Minimum Flow	Maximum Flow	Maximum Pressure
MultiCyclone MC12	12	1 1/2" / 50mm	2.4m ³ /hr	18m ³ /hr	350 kPa 3.5 bar
MultiCyclone MC16	16	2" / 63mm	3m ³ /hr	30m ³ /hr	350 kPa 3.5 bar

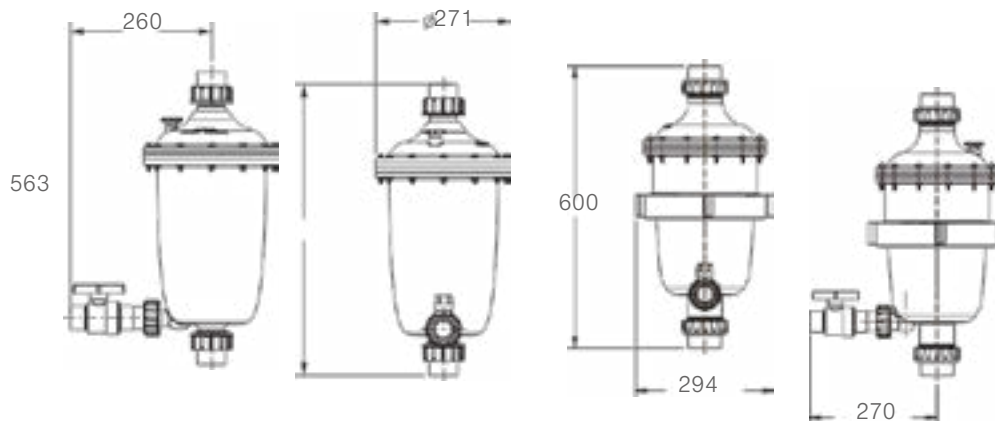



BAYROL - AFM

- + Optimum filtration efficiency
- + Long lasting : lasts 3 times longer than sand
- + Eco-friendly : up to 75% water savings
- + 2 grades - 0.4 - 0.8mm and 0.7mm - 2.0mm



	AFM NG Grade 1 0.4mm - 0.8mm	AFM NG Grade 2 0.7mm - 2.0mm	AFM NG Grade 3 2.0mm - 4.0mm
--	---------------------------------	---------------------------------	---------------------------------

PRODUCT CODE - E

Product Reference	4196641	4196643	4196645
	£ 41.00	£ 41.00	£ 41.00

DESCRIPTION

Contents	AFM Active Filtration Media
Form	Pure
Dosage	Total weight in the filter : 15% less than the equivalent in sand 3mm - 6mm : sufficient to cover the filter laterals 0.5mm - 1mm : in addition, to make up the total weight
Filtration efficiency	Removes 30% more pollutants
Bag net weight	20 kg





BAYROL Eco Filterglass PLUS

- + Optimum filtration efficiency
- + 100% Pure Virgin Glass
- + Long lasting : lasts 3 times longer than sand
- + Eco-friendly : up to 75% water savings



	Eco Filterglass PLUS Grade 1 0.3 - 1.0mm	Eco Filterglass PLUS Grade 2 0.8 - 2.0mm
PRODUCT CODE - E		
Product Reference	4196630	4196631
	£ 29.00	£29.00

DESCRIPTION	
Contents	Filtering medium made of 100% pure virgin glass
Form	Mixed
Dosage	Total weight in the filter : 15% less than the equivalent in sand
Filtration efficiency	Filters down to below 3 microns
Bag net weight	20 kg





Waterco EcoPure - Glass Media

- + Optimum filtration efficiency
- + Long lasting : lasts 3 times longer than sand
- + Eco-friendly : up to 75% water savings
- + 2 grades - 0.5 - 1mm and 3mm - 6mm

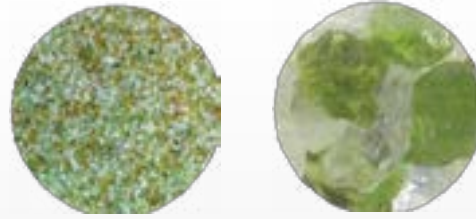

	EcoPure Grade 1 (0.5mm - 1mm)	EcoPure Grade 3 (1mm - 3mm)	EcoPure Grade 3 (3mm - 6mm)
PRODUCT CODE - C			
Standard model	2264/20	2265/20	2266/20
	£ 18.94	£ 18.94	£ 18.94

DESCRIPTION	
Contents	Filtering medium made of 100% recycled glass
Form	Mixed
Dosage	Total weight in the filter : 15% less than the equivalent in sand 3mm - 6mm : sufficient to cover the filter laterals 0.5mm - 1mm : in addition, to make up the total weight
Filtration efficiency	Removes 30% more pollutants
Bag net weight	20 kg



	Filter Sand 16/30 - 25kg	Filter Gravel - 25kg
PRODUCT CODE - E		
Standard model	SAND	GRAVEL
	£ 16.88	£ 16.88



Mini BRIO 2

3 YEAR WARRANTY

- + Perfect integration for an enhanced pool
- + Powerful LED lighting
- + Guaranteed energy savings



TECHNOLOGY
RGBW



	M12 White	M12 Warm	X12 RGBW
PRODUCT CODE - F			
Standard model	CC-A002 RGB	CC-A003 Cool White	CC-A004 Warm white
	£ 295	£ 295	£ 375

ACCESSORIES INCLUDED IN THE PACK



316 Stainless Bezel

DESCRIPTION

Installation Compatibility	1.5" Inlet and without internal reduction (suction cleaner outlet type)		
LED Type	Bright White	RGBW : colour + white	
Operating Mode(s)	1 Fixed colour: white	9 fixed colours & 5 multicolour lighting ambiances	
Colour Choice	Manual (on/off sequences) Remote control with smartphone app available		
Use	Fresh water and salt water up to 6 g/L (6000 ppm)		

TECHNICAL SPECIFICATIONS

Power	12 W	12 W	12 W
Max amperage (A)	0.92	0.92	1.2592
Illuminated surface (m ²)*	20 to 24	20 to 24	20 to 24
Luminous flux (Lumen)	1200	1200	900
LED lifespan **	10 000 h		
Protection rating	IP 68		
Power supply	12 VAC - 50/60 Hz		
Cable length	3 m		

* For a light coloured pool finish. Reduce illuminated surface by roughly 20% for dark pool finishes.

** Theoretical lifespan in hours, for information only.

LIGHT TRANSFORMERS



	100w Transformer (powers 8 x 12w lights)	300w Transformer (powers 25 x 12w lights)
Reference	LH100	LH300
Price	£ 135	£ 155

TECHNICAL SPECIFICATION

Model	Power Supply	Dimensions	Lighting	Lumen	Control
M12 White	12V AC - 50 Hz	Ø49 mm x 63 mm	White	1200 lm	On/Off
M12 Warm	12V AC - 50 Hz	Ø49 mm x 63 mm	Warm Warm	1200 lm	On/Off
X12	12V AC - 50 Hz	Ø49 mm x 63 mm	RGBW	900 lm	RC+ & On/Off

With the new mini Brio LED light generation, try an unmatched powerful and compact solution to light up the pool. With an increased power of up to 50% we propose various possibilities for pool lighting.

Install the mini Brio 2 in CCEI wall conduits and enjoy the benefit of a compact and sleek design solution. Using this hassle free solution there is no need to pull the connection above the water line as the wall conduit is watertight at the back.



ASSOCIATED PRODUCTS



WIFI REMOTE CONTROL

2264/20

£ 280



MID BRIO

3 YEAR WARRANTY

- + Perfect integration for an enhanced pool
- + Powerful LED lighting
- + Guaranteed energy savings
- + M12 versions dimmable



TECHNOLOGY
RGBW



	MID M24	MID M24K	MID X24
--	---------	----------	---------

PRODUCT CODE - F

Standard model	PK10R400	PK10R401	PK10R402
	£ 385	£ 385	£ 495

ASSOCIATED PRODUCTS

NICHE FOR MID BRIO
PF10R322(W)
£ 70

DESCRIPTION

Installation Compatibility	1.5" Inlet	
LED Type	RGBW : colour + white	Bright white
Operating Mode(s)	9 fixed colours & 5 multicolour lighting ambiances	1 fixed colour : white
Colour Choice	Manual (on/off sequences) Remote control with smartphone app available	
Use	Fresh water and salt water up to 6 g/L (6000 ppm)	

TECHNICAL SPECIFICATIONS

Power	24 W	24 W	24 W
Max amperage (A)	1.5	1.5	1.5
Illuminated surface (m ²)*	25 to 30	25 to 30	25 to 30
Luminous flux (Lumen)	2400	2400	1800
LED lifespan **	10 000 h		
Protection rating	IP 68		
Power supply	12 VAC - 50/60 Hz		
Cable length	3 m		

* For a light coloured pool finish. Reduce illuminated surface by roughly 20% for dark pool finishes.

** Theoretical lifespan in hours, for information only.

LIGHT TRANSFORMERS

	100w Transformer (powers 4 x 24w lights)	300w Transformer (powers 12 x 24w lights)
Reference	LH100	LH300
Price	£ 135	£ 155

TECHNICAL SPECIFICATION					
Model	Power Supply	Dimensions	Lighting	Lumen	Control
MID M24	12V AC - 50 Hz	Ø75 mm x 89 mm	White	2400 lm	On/Off
MID M24K	12V AC - 50 Hz	Ø75 mm x 89 mm	Warm Warm	2400 lm	On/Off
MID X24	12V AC - 50 Hz	Ø75 mm x 89 mm	RGBW	1800 lm	RC+ & On/Off

With Mid-BRiO, discover a new generation of lights that are more compact, more powerful and have a wider light beam angle!
 A combination of many technologies, the Mid-BRiO offers an unrivalled power/light/size ratio in the swimming pool market. Light up your pools with a light that has a diameter of just 75 mm and delivers 2,400 lumen.
 The Mid-BRiO fits into standard 1.5" wall conduits and offers a light beam angle of up to 160°: no more dark spots in the pool!



ASSOCIATED PRODUCTS



WIFI REMOTE CONTROL

2264/20

£ 280

BRIO WiL LED Control

3 YEAR
WARRANTY

- + Perfect integration for an enhanced pool
- + Voice control via Alexa
- + APP control via smartphone
- + Wall mounted colour controller

TECHNOLOGY
RGBW



BRIO WiL

PRODUCT CODE - F

Standard model

BRIO WiL

£ 280

DESCRIPTION

Communication	Wifi 802.11 and Bluetooth 4.0
Controlling Power	120W
Operation	Remote control with smartphone app available





BAYROL

your pool & spa water expert

Water treatment

BAYROL	p.79	SPA CHEMICALS	
POOL CHEMICALS		• SpaTime	p.92
• Balancers	p.82	WATER ANALYSIS	
• Disinfection - Chlorine	p.84	• Testers	p.93
• Disinfection - Alternative	p.86	MAINTENANCE EQUIPMENT	
• Disinfection - Shock	p.87	• Maintenance Equipment	p.94
• Algae Prevention	p.88		
• Flocculation	p.89		
• Complementary Products	p.90		
• My Pool Expert APP	p.91		

Pool and Spa Water Treatment

BAYROL has been a true expert in the field of water treatment for swimming pools and spas for over 65 years.

Over the decades, sustainable developments as well as high innovation power combined with operational excellence, have resulted in a product range that meets all the requirements for optimum water care, thus ensuring a high level of customer satisfaction.

Our brand promise: BAYROL offers you the best solution for pool and spa water care.



Making complex things simple!

Since the 1950s, we have been passionate about developing water care products for pools and spas that are efficient and easy to use.

This has resulted in numerous innovations and patents that are well known among pool owners, for instance active oxygen water care in granular form in pre-dosed sachets, and various multifunctional products like the double layer tablet.

For a better understanding and to support pool owners in the best way possible, we have divided water treatment into four essential steps: 1. Water balance 2. Disinfection 3. Algae prevention and 4. Flocculation.

For hygienic reasons, the pool water must always be sanitised. Disinfection is therefore an essential step in water care to which we draw particularly high attention.

Pool and Spa Water Treatment

WE TAKE CARE OF YOUR SAFETY AND WELL-BEING

As experts, we take responsibility for the safety and well-being of our employees and dealers, as well as for the users of our products.

We make sure that all products and packaging meet the highest standards (European and national legislation, child security closing systems, UN certification etc.).

We offer pool owners **the safest products regarding product composition**, for example by excluding heavy metals such as copper sulphate in our formulations.

We continuously seek solutions to reduce risks and inconvenience during the application of our **products** (risk management). Against this background, we have developed the Clorodor Control® capsule in 2016. This capsule is inside all BAYROL chlorine tablet buckets to neutralise the unpleasant smell of chlorine that escapes into the air when opening the bucket, thus avoiding any discomfort.



OUR OBJECTIVE: TO OFFER YOU THE BEST

Our goal is to provide you with pool water care solutions that are as simple, safe and efficient as possible. This can only be achieved through the quality of our products.

Only a few manufacturers in Europe maintain their own research laboratory as we do, where we continuously improve and enhance our product range.

We thoroughly select all raw materials and carefully test our products throughout the process - from production to market launch.

With these high standards, we have been accompanying you as the experts for water treatment in pools and spas for over 65 years.

Balancers

The adjustment of pH is the first stage in obtaining healthy water and the best possible bathing comfort. The correct adjustment of pH between 7.0 and 7.4 (7.4 - 7.6 in case of bromine) is the essential maintenance base of pool water. When the pH is outside these recommended values, the bathing will be less comfortable and the treatment of the following steps will be less efficient. This means that the pH has to be checked at least once a week and, if necessary, adjusted.

PH INCREASER



pH-Plus granules - 5kg
Box qty - 2

pH-Plus granules - 25kg
Qty - 1

PRODUCT CODE - A

Product Reference	5594815	2294817
Unit Price	£ 18.49	£67.90
Box Price	£ 36.97	

PH DECREASER - GRANULES



pH-Minus granules - 6kg
Box qty - 2

pH-Minus granules - 18kg
Qty - 1

PRODUCT CODE - A

Product Reference	5594112	5594114
Unit Price	£ 24.59	£54.45
Box Price	£ 49.18	

PH DECREASER - LIQUIDS



pH-Minus liquid domestic use 14.9%
20L (22kg)
Qty - 1

pH-Minus liquid commercial use 45%
20L (27kg)
Qty - 1

PRODUCT CODE - A

Product Reference	5594328	5594321
	£ 50.96	£66.84

Balancers

ALKALINITY INCREASER



Alca-Plus - 5kg
Box qty - 2

PRODUCT CODE - A

Product Reference	5594524
Unit Price	£ 21.51
Box Price	£ 43.02

HARDNESS INCREASER



Hardness-Plus - 5kg
Box qty - 2

PRODUCT CODE - A

Product Reference	5550001
Unit Price	£ 20.84
Box Price	£ 41.68



CHLORINE TABLETS



Chlorilong® Classic - 5kg Box qty - 2

250g tablets of slow dissolving and regular chlorine for a permanent disinfection. Liberation of uniform chlorine.

PRODUCT CODE - A

Product Reference	5536148
Unit Price	£ 60.50
Box Price	£ 121.00

CHLORINE TABLETS



Chlorilong® Power 5 - 5kg Box qty - 2

250g multifunctional tablets of slow dissolving and regular chlorine for a permanent disinfection.

PRODUCT CODE - A

Product Reference	5599273
Unit Price	£ 62.50
Box Price	£ 125.00

Chlorilong® POWER 5 ensures disinfection to eliminate bacteria and remove turbidity in the pool water, algae destruction, flocculation, hardness and chlorine stabilisation. Place the appropriate amount of tablets in the skimmer. 5 function pool chlorine tablets made from high quality raw materials. A.P.O.® technology guarantees a uniform amount of chlorine during the dissolution period. No gaps in the water disinfection and additional security for clean and safe pool water. Ensures crystal clear water. Does not contain copper sulfate (will not cause damage to the pool surface).

CHLORINE TABLETS



Chlorilong® Ultimate 7 - 4.8kg Box qty - 2

300g multifunctional tablets of slow dissolving and regular chlorine for a permanent disinfection.

PRODUCT CODE - E

Product Reference	5599314
Unit Price	£ 59.07
Box Price	£ 118.14

BAYROL has developed several products that guarantee a more effective disinfection of the water, easily and more complete. These multi-function products cover several stages of the treatment in one action and simplify the maintenance of the pool water. This is the case with Chlorilong Ultimate 7 and its integrated disinfection of the filter.

- 300g tablets of multi-function chlorine for a disinfection in 2 stages: Shock treatment of the sand filter and permanent disinfection of the pool. Superior water quality thanks to its unique formula.
- Patented double layer tablets for a multi-function treatment.
- Dual action dissolution rates: First the filter media and then the pool water.
- Helps to prevent scale formation and biofilm growth in the filter.
- Stabilised chlorine: protection from the UV of sunlight.

CHLORINE GRANULES



Chlorifix - 5kg
Box qty - 2
Fast dissolving stabilised chlorine granules

Chlorifix - 25kg
Qty - 1
Fast dissolving stabilised chlorine granules

PRODUCT CODE - B

Product Reference	5533114	5533135
Unit Price	£ 47.81	£ 244.51
Box Price	£ 95.61	

CHLORINE GRANULES



Chlorifix Shock - 2.4kg
Box qty - 4

PRODUCT CODE - B

Product Reference	5933630
Unit Price	£ 39.74
Box Price	£ 158.95

CHLORINE REDUCER/NEUTRALISER



Chlorine Neutraliser - 5kg
Box qty - 2

PRODUCT CODE - B

Product Reference	4197111
Unit Price	£ 38.97
Box Price	£ 77.94



Disinfection

ABOVE GROUND POOLS



Mini Pool Monthly set - 630g
Box qty - 6

4 x double sachets containing Multifunctional Chlorine Granules and Algicide.

PRODUCT CODE - B

Product Reference	1199011
Unit Price	£ 23.01
Box Price	£ 138.03

BROMINE TABLETS



Aquabrome® - 20g slow dissolving tablets - 5kg
Box qty - 2

PRODUCT CODE - B

Product Reference	3639338
Unit Price	£ 116.82
Box Price	£ 233.64

ACTIVE OXYGEN



Soft & Easy 20m3 - 4.48kg
Box qty - 2

Soft & Easy 30m3 - 5.04kg
Box qty - 2

PRODUCT CODE - F

Product Reference	4199227	4199220
Unit Price	£ 63.09	£ 70.95
Box Price	£ 126.18	£ 141.90

ACTIVE OXYGEN



Bayrosoft® 22 kg
Qty - 1

Bayroshock® - 5.0L
Box qty - 2

PRODUCT CODE - B

Product Reference	5532246	5532292
Unit Price	£ 127.88	£ 27.19
Box Price		£ 54.38



Disinfection

SHOCK CHLORINE



SPLASH Shock Chlorine
1 kg Box Qty - 12

SPLASH Shock Chlorine
2 kg Box Qty - 6

SPLASH Shock Chlorine
5 kg Box Qty - 2

PRODUCT CODE - E

Product Reference	SPL-SC001	SPL-SC002	SPL-SC005
Unit Price	£ 22.00	£ 38.00	£ 61.00
Box Price	£ 264.00	£ 228.00	£ 122.00

RAPID SHOCK



SPLASH Ultra Rapid Power Shock 4kg
Box Qty - 2

PRODUCT CODE - E

Product Reference	SPL-URS004
Unit Price	£ 98.00
Box Price	£ 196.00

CALCIUM HYPOCHLORITE



Calcium Hypochlorite Granules - 25kg

PRODUCT CODE - E

Product Reference	SPL-CAL025
Unit Price	£ 203

LIQUID CHLORINE



Sodium Hypochlorite
14/15% 5L

Sodium Hypochlorite
14/15% 10L

Sodium Hypochlorite
14/15% 20L

PRODUCT CODE - E

Product Reference	SPL-SH005	SPL-SH010	SPL-SH020
	£ 18.00	£ 25.00	£ 34.00

NON-CHLORINE SHOCK



Splash Non Chlorine Shock 1kg
Box Qty - 12

Splash Non Chlorine Shock 5kg
Box Qty - 4

PRODUCT CODE - E

Product Reference	SPL-NCS001	SPL-NCS005
Unit Price	£ 34.00	£90.00
Box Price	£ 408.00	£ 360.00



Algae Prevention

- The BAYROL formulas for algae prevention have a large spectrum of actions and have an effect against all types of algae. They are very concentrated which makes them extremely effective, even in a small dosage. All the Desalgine products are without chlorine and without heavy metals (notably without copper sulphate).
- Effective: Long duration (concentrated formula).
- Without risk for the surfaces: Without copper sulphate.
- Clarifying effect.
- Non-foaming formula. Ideal for pools with water features and/ or flumes.

ALGAECIDE		
	Desalgine® Jet - 1L Box qty - 12	Desalgine® Jet - 3L Box qty - 2
PRODUCT CODE - A		
Product Reference	5541510	5541502
Unit Price	£ 22.14	£ 60.99
Box Price	£ 265.68	£ 121.98

WINTER ALGAECIDE		
	Puripool® Super - 1L Box qty - 12	Puripool® Super - 3L Box qty - 2
PRODUCT CODE - E		
Product Reference	5543169	5543163
Unit Price	£ 13.19	£ 37.19
Box Price	£ 158.22	£ 74.38



Flocculation

FLOCCULATION CARTRIDGES



Superflock Plus - 1kg
Box qty - 8

PRODUCT CODE - B

Product Reference	5595292
Unit Price	£ 37.05
Box Price	£ 296.39

- Flocculation guarantees clear water. It allows very fine particles to be trapped in the filter media, so that it doesn't go back into the pool. These materials are eliminated during filter backwashes. For pools equipped with a cartridge filter, BAYROL proposes to use a clarifier.
- A flexible cartridge of flocculation product especially for sand/glass filters to effectively and constantly battle against cloudy water.
- Eliminates metals and phosphates.
- Easy to use pre-dosed cartridges.
- Slow dissolving and prolonged action for permanent crystal clear water.
- When used regularly, it allows a saving in the usage of disinfectant products.
- Eliminates discoloration due to copper or iron and prevents stains.
- Restricts the growth of algae.

CLARIFIER LIQUID



SuperKlar - 0.5L
Box qty - 12

PRODUCT CODE - B

Product Reference	5595329
Unit Price	£ 27.79
Box Price	£ 333.43

Concentrated liquid with a quick clarifying effect.
Compatible with cartridge filters. Easy usage and dosing.

FLOCCULATION LIQUID



Quickflock - 20 ltr
Qty - 1

Quickflock Automatic Plus - 20 ltr
Qty - 1

PRODUCT CODE - A

Product Reference	5595179	4195129
Unit Price	£ 58.00	£ 74.96

Liquid flocculant with fast clarifying effect especially for sand filters. The ideal solution for severely clouded water. Quickflock Automatic Plus is for automatic dosing.



Complementary Products

CALCIUM PREVENTION



Calcinex - 1L
Box qty - 12

PRODUCT CODE - B

Product Reference	5518149
Unit Price	£ 25.40
Box Price	£ 304.75

ACIDIC CLEANER



Decalcit Super - 3L
Box qty - 2

PRODUCT CODE - B

Product Reference	5513281
Unit Price	£ 26.00
Box Price	£ 51.99

WATERLINE CLEANER



Bordnet - 1L
Box qty - 6

PRODUCT CODE - B

Product Reference	5515417
Unit Price	£ 18.52
Box Price	£ 111.14

WATERLINE CLEANER



Protect & Shine - 2L
Box qty - 4

PRODUCT CODE - B

Product Reference	4195351
Unit Price	£ 22.41
Box Price	£ 89.63

FILTER CLEANER



Filterclean Tab - 1kg
Box qty - 6

PRODUCT CODE - C

Product Reference	5513119
Unit Price	£ 23.05
Box Price	£ 138.32

MY POOL EXPERT APP

- My Pool Expert is the smart app for pool maintenance
- Access useful information about your pool maintenance from any smartphone, tablet or computer
- Enter the pool details and test results for a bespoke report
- Advice on how to fix problems with the pool water
- Free to download or use in a web browser
- Saved history of reports and test results

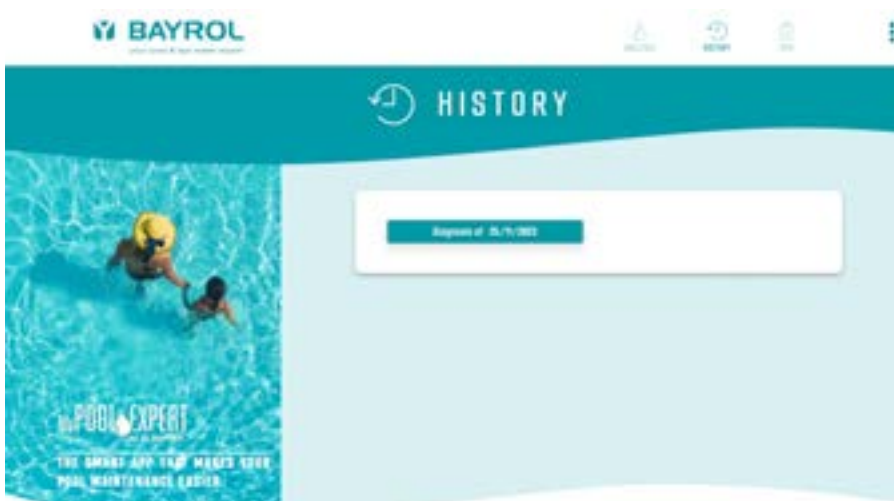
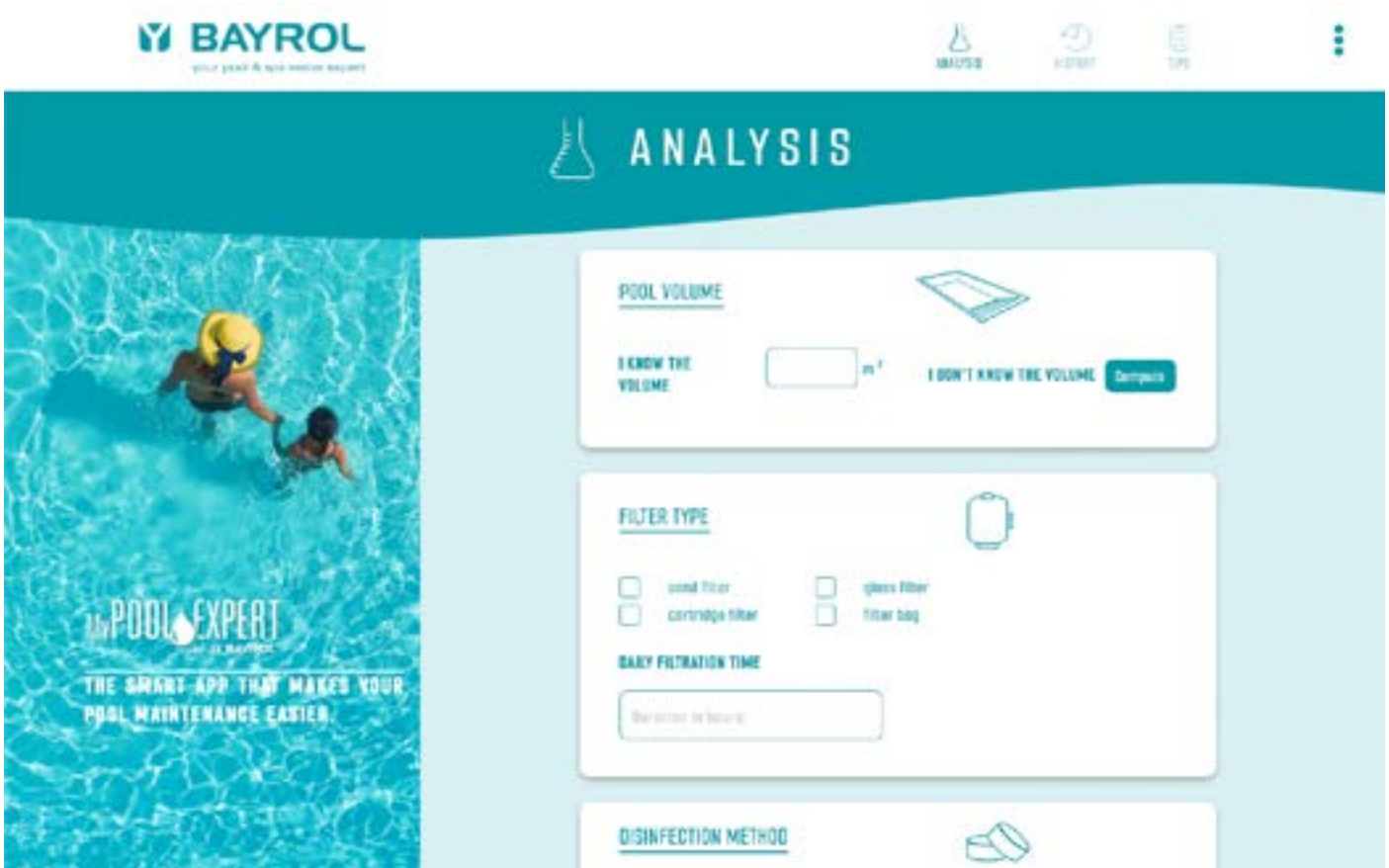



Spa Time

SANITISERS - CHLORINE



Chlorine Granules - 1kg
Box qty - 12

Chlorine Tablets 20g - 1kg
Box qty - 12

Spa Pure Shock
(Box 4 x 36 sachets)
Box qty - 24

PRODUCT CODE - B

Product Reference	5533150	5536101	5537850
Unit Price	£ 17.07	£ 20.91	£ 22.11
Box Price	£ 204.92	£ 250.97	£ 265.31

SANITISERS - NON CHLORINE



Bromine Tablets 20g -
0.8kg
Box qty - 12

Active Oxygen Granules - 1kg
Box qty - 12

Active Oxygen
Activator - 1L
Box qty - 12

PRODUCT CODE - B

Product Reference	5539350	5532150	5541600
Unit Price	£ 39.74	£ 28.10	£ 20.32
Box Price	£ 476.85	£ 337.02	£ 243.80

BALANCERS



pH-Plus - 1kg
Box qty - 12

pH-Minus - 1kg
Box qty - 12

Alca-Plus - 1kg
Box qty - 6

Hardness Stabiliser
- 1kg
Box qty - 6

PRODUCT CODE - B

Product Reference	5594550	5594150	5594540	5518200
Unit Price	£ 9.90	£ 10.76	£ 10.75	£ 17.02
Box Price	£ 118.85	£ 129.07	£ 64.54	£ 102.15

SHOWROOM DISPLAY



Showroom Display

POA

Spa Time

COMPLIMENTARY PRODUCTS



Filter Cleaner - 800 g Box qty - 6	Surface Cleaner - 1L Box qty - 6	Anti foam - 1L Box qty - 6	Clarifier - 1L Box qty - 6	Pipework Cleaner - 1L Box qty - 6	5 Way Test Strips x 50 Box qty - 6
---------------------------------------	-------------------------------------	-------------------------------	-------------------------------	--------------------------------------	---------------------------------------

PRODUCT CODE - B

Product Reference	5596673	5515472	5545200	5595300	5512201	288220
Unit Price	£ 21.17	£ 16.39	£ 17.33	£ 17.08	£ 21.52	£ 23.01
Box Price	£ 127.05	£ 98.36	£ 103.97	£ 102.46	£ 129.10	£ 138.06

Water Analysis

TEST STRIPS



QuickTest Strips pH/CL/TA plus Algaecide Box qty - 12	Bayrosoft® QuickTest Test Strips pH/O2/TA Box qty - 6	Aquabrome® Quicktest Test Strips pH/BR Box qty - 12	Naturally Salt Quicktest test strips Box qty - 12	Phosphate Test Strips Box qty - 6
--	--	--	--	--------------------------------------

PRODUCT CODE - C

Product Reference	288023	288015	288025	288223	328812
Unit Price	£ 18.30	£ 28.00	£ 23.84	£ 21.90	£ 31.05
Box Price	£ 219.54	£ 167.98	£ 286.07	£ 262.79	£ 186.28

POOLTESTER



Pooltester DPD - pH/Chlorine Box qty - 6	Pooltester DPD - pH/Bromine Box qty - 6	Pooltester DPD - pH/O2 Box qty - 6	DPD 1 Rapid Tablets for Pool Tester - 250 Qty - 1	Phenol Red Tablets for Pool Tester - 250 Qty - 1
---	--	---------------------------------------	---	--

PRODUCT CODE - C

Product Reference	287123	287126	287988	287151	291307
Unit Price	£ 27.45	£ 25.22	£ 36.87	£ 20.79	£ 17.19
Box Price	£ 164.66	£ 151.35	£ 221.21		



BAYROL Maintenance Equipment



	Digital Thermometer Box Qty - 6	18 cm Thermometer Box Qty - 12	Floating Thermometer Box Qty - 6
PRODUCT CODE - F			
Product Reference	411036	411000	411026
Unit Price	£ 27.49	£ 9.35	£19.99
Box Price	£149.94	£ 102.00	£ 119.94



	Leaf Net Box Qty - 6	Bottom Rake Net Box Qty - 6
PRODUCT CODE - F		
Product Reference	411001	411032
Unit Price	£ 19.78	£ 24.75
Box Price	£ 107.94	£ 135.00



	25 cm - Polypropylene Brush - Box Qty 6	25 cm - Stainless Steel Brush - Box Qty 6	50 cm - polypropylene Brush - Box Qty 6	50 cm - Rubber Brush - Box Qty 6	45 cm - Stainless Steel Brush - Box Qty 6
PRODUCT CODE - F					
Product Reference	411005	411006	411025	411024	411019
Unit Price	£ 17.05	£ 20.35	£ 21.45	£ 24.75	£ 26.40
Box Price	£ 93.00	£111.00	£ 117.00	£ 135.00	£ 144.00



	Corner Brush Box Qty - 6	Waterline Brush Box Qty - 12	Waterline Sponge x 3 Box Qty - 12
PRODUCT CODE - F			
Product Reference	411008	411009	411028
Unit Price	£ 15.40	£ 13.75	£ 8.80
Box Price	£ 84.00	£ 150.00	£ 96.00



	Floating Chlorine Dispenser Box Qty - 6
PRODUCT CODE - F	
Product Reference	411037
Unit Price	£ 13.20
Box Price	£ 72.00



BAYROL Maintenance Equipment



8m Vacuum Hose

10m Vacuum Hose

PRODUCT CODE - F

Product Reference	411023	411011
	£ 58.00	£ 72.00



Rectangular Vacuum Head
Box Qty - 6

Triangular Vacuum Head
Box Qty - 6

PRODUCT CODE - F

Product Reference	411034	411018
Unit Price	£ 36.30	£ 39.60
Box Price	£ 198.00	£ 216.00



Telescopic Pole - 2 pieces, Maximum length 4.5m - Box Qty 6

PRODUCT CODE - F

Product Reference	411020
Unit Price	£ 46.20
Box Price	£ 252.00



Multipurpose Equipment Rack
Box Qty - 4

PRODUCT CODE - F

Product Reference	411014
Unit Price	£ 97.90
Box Price	£ 356.00



Complete BAYROL Maintenance Starter Pack
Includes: 1 x Vac Hose 10m, 1 Vac Pole, 1 x Deep Net, 1 x Leaf Net,
1 x 50cm Polypropylene Brush, 1 x Vacuum Head, 1 x 18cm Thermometer,
1 x Waterline Brush, 1 x Floating Dispenser, 1 x BAYROL Pooltester DPD/pH,
1 x Multipurpose Equipment Rack

PRODUCT CODE - F

Product Reference	BY-Main-Kit
	£ 315.00



Waterco AquaFingers - Microfibre broom

- + Premium microfibre chenille attachment is gentle on smooth surfaces
- + Flexible head easily dislodges particles from tight areas
- + Ideal for cleaning fibreglass, tiled and vinyl lined pools
- + Suitable for cleaning pool covers and glass fences
- + Replacement chenille attachment available



	Aqua Fingers Complete - Box Qty 12	Aqua Fingers Microfibre Replacement Cover - Box Qty 12
PRODUCT CODE - F		
Standard model	313300	31331
Unit Price	£ 40.35	£ 27.12
Box Price	£ 484.44	£ 325.44



Large surface area for effective cleaning



High-density of chenilles for enhanced performance

Flexible body for curves and ridges

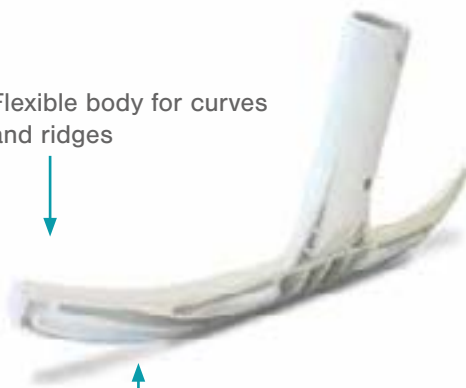

Curved underbelly to allow more angles of operation

Large water flow gaps



Reinforced neck for superior durability



DOSING

SALT CHLORINATORS	p.98	BAYROL TECHNIK	p.110
• BAYROL Automatic Salt	p.99	• Compact Controller	p.111
• BAYROL Smart&Easy	p.100	• Analyt Controller	p.112
• Mini Salt	p.102	• Pool Manager	p.114
• Just Salt	p.103	• Pool Relax	p.115
UV SYSTEMS	p.104	• Flockmatic	p.116
• Mini UV	p.104	• Dosing Pumps	p.117
• Just Salt UV	p.105	• Dosing Accessories	p.118
• H.R. UV-C	p.106		
• Quantum	p.107		
PH AND CHLORINE DOSING - DOMESTIC	p.108		
• BAYROL Automatic pH	p.108		
• BAYROL Automatic Cl/pH	p.109		



BAYROL Automatic Salt



Automatic SALT is the smart salt electrolysis product from the research and development work of Bayrol Technik, produced and developed in Germany. It regulates the production of chlorine from the salt dissolved in the water. It also measures and regulates the pH which ensures a safe, sustainable and more environmentally friendly treatment of your pool water: optimal water quality without the risk of overdosing chlorine.

The Smart&Easy technology makes Automatic Salt an ideal companion to give you undisturbed and safe bathing pleasure. The large display and the menu navigation, which is easy to understand even for inexperienced users, is a joy to operate. Automatic Salt has intelligent software functions, such as the initial commissioning wizard which helps you to easily define the essential parameters of the device. In operation, this gives useful tips for occurring status messages.

Automatic Salt automatically and precisely analyses the pH value and the chlorine content (redox) and regulates them by injecting liquid pH and by generating free chlorine with the help of salt electrolysis. This ensures a stable water balance and thus enables a steady disinfection performance with the optimal chlorine content. The electrolysis cell can also produce free chlorine from a salt content of only 1.5 g/l and the technical and high-quality design makes it easy to integrate into the existing pool system.

In combination with the included Smart&Easy Connector, Automatic Salt is completed. This enables easy installation of all sensors and is compact and spacesaving. The integrated flow switch and temperature sensors provide additional safety and pool information on the device.

Automatic Salt is equipped as standard with an integrated WiFi module that allows convenient remote access to the pool water parameters via a smartphone or any other Internet-enabled device. The remote access allows not only a reading of the measured values but also full access to the settings - so you have your pool water quality fully under control even on the go.



Smart&Easy connector
- a BAYROL innovation



BAYROL Automatic Salt - Salt chlorinator with pH + ORP

- + Regulates pH and chlorine production
- + Salinity of only 1.5 g/l minimum
- + Care with chlorine by means of salt electrolysis
- + For private pools
- + Efficient, high performance electrolysis cells for pools up to 140 m3
- + Integrated WiFi for use with BAYROL web portal



	Automatic Salt AS 5	Automatic Salt AS 7
PRODUCT CODE - F		
Standard model	191500	191700
	£ 2,725	£ 2,857

FOR WHICH POOL?		
	Automatic Salt AS 5	Automatic Salt AS 7
Volume of treated water (temperate climate, 8h/day filtration)	80 m³	140 m³

DESCRIPTION	
User interface	4.3» TFT colour touchscreen
Operating modes	Auto, Auto Plus+, Constant production, Safe, Pause, Boost
pH Regulation	Yes
ORP Regulation	Yes
Timer	Internal
Polarity reversal	Yes - Adjustable
Required salt level - minimum	1.5g/l Minimum up to 40g/l Maximum
Cell position	Horizontal or vertical
Plumbing compatibility	DN50 mm

ASSOCIATED PRODUCTS

Hydrosoft BPR compliant Salt (25kg bag)	Bayrol pH-Minus liquid 14.9%	25l Bund Tank
Salt25	5594328	HFK-A81
£ 32	£ 50.96	£ 135.00





BAYROL Smart&Easy - control module



- + Optional add on for Automatic Salt
- + DIN Rail Mounted
- + Switch functions via Automatic Salt (Filter pump, lights...)
- + Variable speed pump control
- + Control of pool via app or unit
- + Integrated WiFi for use with BAYROL web portal
- + 4 x mechanical relays, 4 x digital relays (for VSP)



	Smart&Easy Control Module	Smart&Easy Box inc Module
PRODUCT CODE - F		
Standard model	191080	191081
	£ 590	£ 890

DESCRIPTION	
User interface	Via App and on Automatic unit
Operating modes	4 x mechanical relays, 4 x digital relays (for VSP)
Power	230v Single phas
Timer	Yes via app and Automatic unit

ASSOCIATED PRODUCTS



Automatic Salt

Page





BAYROL Smart&Easy - control module for Automatic Salt





Mini Salt - Salt Chlorinator

2 YEAR
WARRANTY

- + Intuitive navigator on LED display
- + Light and compact
- + Normal and Low Salt options
- + High quality titanium cell



Pool
TECHNOLOGIE

Mini Salt 4

Mini Salt 8

Mini Salt 12

Mini Salt 16

Mini Salt 23

Mini Salt 30

PRODUCT CODE - F

Standard model	ELLY20NPSB-GONM04	ELLY20NPSB-GONM08	ELLY20NPSB-GONM12	ELLY20NPSB-GONM16	ELLY20NPSB-GONM23	ELLY20NPSB-GONM30
	£ 982	£ 1,025	£ 1,279	£ 1,444	£ 1,731	£ 2,091

FOR WHICH POOL?

	Mini Salt 4	Mini Salt 8	Mini Salt 12	Mini Salt 16	Mini Salt 23	Mini Salt 30
Volume of treated water (temperate climate, 8h/day filtration)	20 m ³	40 m ³	60 m ³	80 m ³	120 m ³	160 m ³
Low Salt Volume of treated water (temperate climate, 8h/day filtration)				60 m ³	80 m ³	120 m ³
Nominal chlorine production	4 g/h	8 g/h	12 g/h	16g/h	23g/h	30 g/h
Low salt chlorine production				12 g/h	16g/h	23g/h
Nominal output Amps	0.2 A	0.4 A		0.8 A	0.9A	0.9 A

DESCRIPTION

User interface	LED and Buttons
Operating modes	Normal, Boost (100% during 24h) & Low (adjustable cover mode from 10 to 90 %)
pH Regulation	No
ORP Regulation	No
Timer	Controlled by filtration timer
Polarity reversal	Yes : Adjustment from 2h to 16h by steps of 2h
Required salt level - minimum	2.5 g/L Normal Salt - 1.5 g/L Low Salt
Cell position	Horizontal or vertical
Plumbing compatibility	DN50 mm, DN63 mm

ASSOCIATED PRODUCTS



Hydrossoft BPR compliant Salt (25kg bag)

Salt25

£ 32



Just Salt - Salt Chlorinator

- + Display of salt level, water temperature and cell life
- + Superboost mode
- + Normal and Low Salt
- + High quality titanium cell
- + Bluetooth control with e-pool app



2 YEAR
WARRANTY

	Just Salt 8	Just Salt 12	Just Salt 16	Just Salt 23	Just Salt 30
PRODUCT CODE - E					
Standard model	ELLY20NPSA-G4NM08	ELLY20NPSA-G4NM12	ELLY20NPSA-G4HX16	ELLY20NPSA-G4HX23	ELLY20NPSA-G4HX30
	£ 1,367	£ 1,494	£ 1,804	£ 2,099	£ 2,430

FOR WHICH POOL?

	Just Salt 8	Just Salt 12	Just Salt 16	Just Salt 23	Just Salt 30
Volume of treated water (temperate climate, 8h/day filtration)	40 m ³	60 m ³	80 m ³	120 m ³	160 m ³
Low Salt Volume of treated water (temperate climate, 8h/day filtration)			60 m ³	80 m ³	120 m ³
Nominal chlorine production	8 g/h	12 g/h	16g/h	23g/h	30 g/h
Low salt chlorine production			12 g/h	16g/h	23g/h

DESCRIPTION

User interface	LCD Display
Operating modes	Normal, Boost (100% during 24h) & Low (adjustable cover mode from 10 to 90 %)
Timer	Controlled by filtration timer
Polarity reversal	Yes : Adjustment from 2h to 16h by steps of 2h
Required salt level - minimum	2.5 g/L Normal Salt - 1.5 g/L Low Salt
Cell position	Horizontal or vertical
Plumbing compatibility	DN50 mm, DN63 mm

ASSOCIATED PRODUCTS



Hydrosalt BPR compliant Salt (25kg bag)

Salt25

£ 32



Mini UV - UV steriliser

- + Up to 35% higher UV-C efficiency
- + Duplex stainless steel reactor
- + High quality softglass UV lamp
- + Compatible with Ø 63 mm and Ø 50 mm pipes
- + 2 models available : 40W and 80W lamp
- + Compact, ideal for small technical rooms
- + Compatible with Just Dosing

2 YEAR WARRANTY



Pool TECHNOLOGIE





	Mini UV 40	Mini UV 80
PRODUCT CODE - F		
Standard model	STUV23NPSB-40	STUV23NPSB-80
	£ 461	£ 508

FOR WHICH POOL?		
	Mini UV 40	Mini UV 80
Volume of treated water (temperate climate, 8h/day filtration)	50 m ³	100 m ³

DESCRIPTION	
Reactor material	316 L stainless steel
UV lamp lifespan	9 000 hours
UV lamp power (W)	40 or 80
Sealing ballast index	IP65
Reactor diameter (mm)	70
Reactor height (mm)	1000
Reactor weight (kg)	3,3

ASSOCIATED PRODUCTS

	
Automatic pH	Automatic Cl/pH
150100	150200
Page 108	Page 109



Justsalt UV - UV/Ultra Low Salt Hybrid

- + Ultra Low Salt® technology: operate at any salt level higher 0,5 g/l
- + New reactor design consisting of a UV lamp and a ULS® electrode
- + Installation of the electrode at the reactor outlet
- + Integrated flow sensor
- + Drain valve at the base of the reactor
- + Simplified maintenance of the electrode
- + Compatible with Just pH

2 YEAR
WARRANTY



	Justsalt UV 15	Justsalt UV 25
PRODUCT CODE - F		
Standard model	ELLY23NPSP-G0VX15	ELLY23NPSP-G0VX25
	£ 2,623	£ 2,885

FOR WHICH POOL?		
	Justsalt UV 15	Justsalt UV 25
Volume of treated water (temperate climate, 8h/day filtration)	50 m³	100 m³

DESCRIPTION	
Display	LED display
Polarity inversion adjustment	from 2h to 16h in increments of 2h
UV lamp power (W)	60 or 90
UV wavelength	254 nm
UV lamp lifespan	16 000 hours*
Reactor height (mm)	787 (50m3) / 1087 (100m3)
Reactor diameter (mm)	350
Control panel size (mm)	W 266 x H 363 x D 167

ASSOCIATED PRODUCTS



Automatic pH

150100

Page 108



H.R. UV-C - UV steriliser

- + Highest UV reflective index on the market equating to supreme efficiency
- + E-PTFE reaction chamber is extremely repellent, maintaining UV reflectivity
- + Up to 95% reflection amplifying the exposure of micro-organisms to UV
- + Reduces the need for chemicals in the pool by up to 60%
- + No harmful gases or by-products produced
- + Powerful sterilisation and eliminates the smell of chlorine
- + Average lamp life expectancy: 2 years
- + Equipped with intelligent lamp life indicator
- + Fresh, sea and salt chlorinated water compatible



	Mini Standard	Mini Classic	Single Standard	Single Classic	Double Standard	Double Classic
PRODUCT CODE - F						
Standard model	HR-30-B	HR-30-UK	HR-55-B	HR-55-UK	HR-110-B	HR-110-UK
	£ 383	£ 525	£ 430	£ 570	£ 661	£ 818



FOR WHICH POOL?

	Mini Standard	Mini Classic	Single Standard	Single Classic	Double Standard	Double Classic
Volume of treated water (temperate climate, 8h/day filtration)	30 m ³	30 m ³	55 m ³	55 m ³	110 m ³	110 m ³

DESCRIPTION

Reactor material	316 L stainless steel
UV lamp lifespan	9 000 hours
UV lamp power (W)	40w, 64w, 128w
Sealing ballast index	IP65
Water Connections	2»/63mm stepped ABS unions + reducers 1.5»/50mm
Mounting	Vertical or Horizontal

ASSOCIATED PRODUCTS

	
Automatic pH	Automatic Cl/pH
150100	150200
Page 108	Page 109



QUANTUM

- + Photocatalytic TiO₂/Mo oxidiser and clarifier
- + Combined photocatalytic, hydroxyl radical and UV technology
- + Eliminates contaminants, leaving water looking clean, fresh and crystal clear
- + Reduces the need for chemicals in the pool by up to 80%
- + Keeps your family safe from dangerous micro-organisms such as cryptosporidium, adenoviruses and naegleria fowleri
- + Optional smart peristaltic dosing system for chlorine, hydrogen peroxide (Pro model only)
- + Powerful sterilisation and eliminates the smell of chlorine
- + Average lamp life expectancy: 2 years
- + Equipped with intelligent lamp life indicator
- + Fresh, sea and salt chlorinated water compatible
- + Three sizes available: Mini (35m³), Single (65m³) & Double (130m³)





	Mini Classic	Single Classic	Double Classic
PRODUCT CODE - F			
Standard model	Q-35-UK	Q-65-UK	Q-130-UK
	£ 884	£ 1,030	£ 1,364

FOR WHICH POOL?			
Volume of treated water (temperate climate, 8h/day filtration)	35 m ³	65 m ³	130 m ³

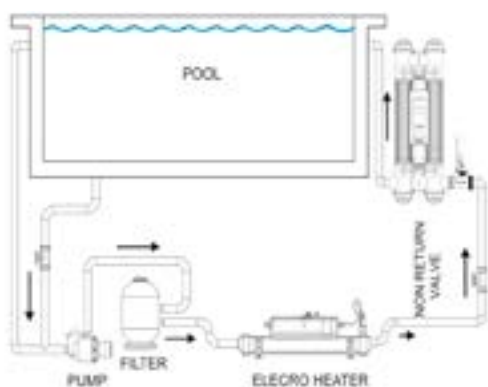
DESCRIPTION	
Reactor material	316 L stainless steel
UV lamp lifespan	14 000 hours
UV lamp power (W)	40w, 64w, 128w
Sealing ballast index	IP64
Water Connections	2»/63mm stepped ABS unions + reducers 1.5»/50mm
Mounting	Vertical or Horizontal



ASSOCIATED PRODUCTS

	
Automatic pH	Automatic Cl/pH
150100	150200
Page 108	Page 109



BAYROL Automatic pH - pH Dosing



- + Analyses and regulates pH
- + Utilises Smart&Easy technology
- + Perfect for private pools
- + Operates with pH minus and pH plus
- + Integrated WiFi for use with BAYROL web portal



EASY
INSTALLATION

Automatic pH

PRODUCT CODE - F

Standard model 150100

£ 999

FOR WHICH POOL?

	Automatic pH
Volume of treated water (temperate climate, 8h/day filtration)	90 m ³

DESCRIPTION

User interface	4.3» TFT colour touchscreen
Security	High and Low measuring alarm, Dosing time alarm
pH Regulation	Yes
ORP Regulation	No
Timer	Internal
Maximum production	2.4 l/hr
Plumbing compatibility	DN50 mm

ASSOCIATED PRODUCTS



Bayrol pH-Plus

5594817

£ 36.97



Bayrol pH-Minus liquid 14.9%

5594328

£ 50.96



Smart&Easy Connector

150060

£ 278.88



25l Bund Tank

HFK-A81

£ 135.00



BAYROL Automatic Cl/pH - pH and ORP Dosing

- + Analyses and regulates pH and Chlorine
- + Utilises Safe and Easy technology
- + Perfect for private pools
- + Operates with pH minus and pH plus
- + Integrated WiFi for use with BAYROL web portal



Automatic pH/Cl

PRODUCT CODE - F

Standard model	150200
----------------	--------

£ 1,599



FOR WHICH POOL?

	Automatic pH/Cl
Volume of treated water (temperate climate, 8h/day filtration)	90 m ³

DESCRIPTION

User interface	4.3» TFT colour touchscreen
Security	High and Low measuring alarm, Dosing time alarm
pH Regulation	Yes
ORP Regulation	Yes
Timer	Internal
Maximum production	2.4 l/hr
Plumbing compatibility	DN50 mm

ASSOCIATED PRODUCTS

			
Bayrol pH-Plus	Bayrol pH-Minus liquid 14.9%	Sodium Hypochlorite 14/15%	Smart&Easy Connector
5594817	5594328	SPL-SH020	150060
£ 36.97	£ 50.96	£ 34.00	£ 278.88



25l Bund Tank
HFK-A81
£ 135.00



BAYROL

TECHNIK

BAYROL Technik solutions for automatic water care

Containing a great deal of know-how and expertise, BAYROL Technik offers a range of reliable and premium quality systems for the automatic measurement, control and dosing of liquid products for pool water care.

No matter whether you want to maintain your pool with salt, liquid chlorine, bromine or active oxygen, our range contains the perfect automatic solution to meet your requirements.

For water treatment with chlorine, bromine or active oxygen:

- **Economy class** featuring **Automatic Cl/pH** includes devices that incorporate BAYROL's know-how for a simple and efficient automatic water care.
- **Functional class** featuring **PoolRelax®** for the best water quality. Offers switch functions in addition to automatic measuring and dosing.
- **Premium class** featuring the **PoolManager®** range, a state-of-the-art device that also allows the remote control of your entire pool.

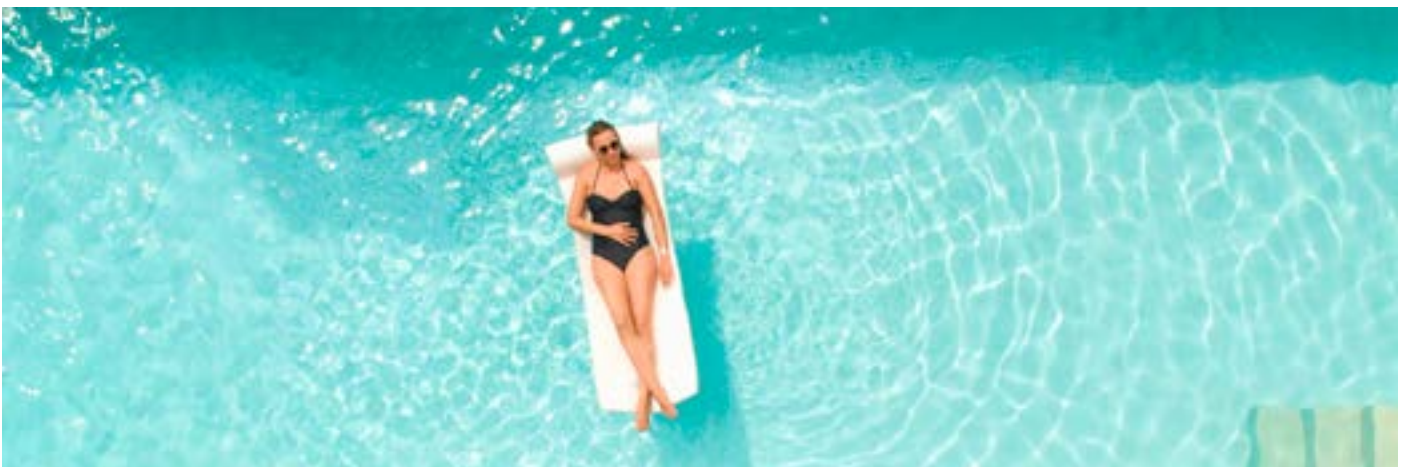



Compact Controller

- + Large colour touch screen
- + Cleverly structured menu
- + Online help
- + Interfaces
- + Graphic display of readings
- + Event log
- + Highly sensitive measuring equipment
- + Prefilter
- + Optional web connectivity



Compact Controller mk3 - free chlorine, pH, Temperature, colour touchscreen

Compact Controller mk3 - flow control

PRODUCT CODE - E

Standard model	176999	176998
	£ 3,587	£ 3,828

DESCRIPTION

The Compact Controller combines the highest technological standard with optimal ease of use. A large colour touch display in 5" wide screen format combined with logical menu structure provides very simple and clear operation.

A single touch on the screen is all you need to access the individual menu items or change a setting. All the relevant data is displayed in clear text and can be registered at a glance.

The menu can be displayed in the following languages: German, English, French, Spanish, Italian, Polish, Greek, Russian, Flemish, Slovakian, Latvian, Danish, Swedish, Hungarian, Portuguese and Croatian. The menu is well-structured and the system is easy to use and understand.

Each menu item is also provided with context-related, meaningful help texts. Combined with its robust design, this means high functionality and the greatest possible reliability.

ASSOCIATED PRODUCTS

Bayrol pH-Minus liquid 45%	Bayrol pH-Minus liquid 14.9%	Sodium Hypochlorite 14/15%	Web Module for Compact Controller
5594321	5594328	SPL-SH020	174935
£ 66.84	£ 50.96	£ 34.00	£ 497.00

Eatron DLX Pumps	25l Bund Tank
Page - 117	HFK-A81
	£ 135.00



Analyt Controller

- + Easy, intuitive operation using a touch screen
- + Wide range of connection options for control of external devices.
- + Measures pH and chlorine/bromine levels (Analyt 3 also measures redox)
- + Extensive alarm functions which can be set acoustically, visually, via relay outputs, or as emails (if internet connection is available).
- + Long-term log book function for recording pool's operating history.
- + Pressure resistant, potentiostatic gold/platinum measuring cell for accurate measurement of chlorine content
- + Easy calibration and maintenance of chlorine measuring cell
- + 4 universal switching inputs (potential-free)
- + The flow rate of the dosing pumps can be put in the software in order to calculate the dosage
- + Dosing pumps are controlled via an On/Off signal; individual strokes of diaphragm dosing pumps can be controlled directly from the device.
- + Eco mode switches off display when not needed



	Analyt 2 pH/Cl	Analyt 3 pH/Cl/Rx
PRODUCT CODE - E		
Standard model	177600	177800
	£ 5,446	£ 6,433

DESCRIPTION

The latest Analyt is a highly efficient and precise automatic measurement, control and dosing system for swimming pool water care.

Its wide range of connection options for external devices means that it can also act as the main control unit for a swimming pool. It can be used to control the pool's circulation pump, lighting, heating, and much more. As a result, many control equipment items are no longer needed, noticeably reducing costs. This ensures high functionality and the greatest possible reliability.













Analyt Controller

ANALYT CONTROLLER TECHNICAL SPECIFICATIONS

Display	High definition TFT display with VGA resolution (800 x 400) graphics-capable, aspect ratio 16:9
User interface	Touch screen, icon-based, menus 5 hotkeys for frequent actions, comprehensive help function
Security	5 password levels, configurable for direct and remote access
Available languages	Choice of 16 languages
Measurement parameters / ranges	pH 0 – 10 (temperature-compensated) Redox 0 – 1,000 mV (Analyt 3 only) Free chlorine 0.01 – 10 pm/mg/l Temperature 2 x 0-50 °C, 1 x 0-75 °C
Measurement tolerances	pH, chlorine and redox (Analyt 3 only): max. +/-2% of full scale Temperature: max. +/- 0.5 °C
Measurement input	pH, redox (PoolManager® PRO: free chlorine) and temperature
regulating	Proportional Regulation
Inputs / outputs	4 universal switching inputs (potential free) 4 universal relay switching outputs, potential-free or 230 V~ (max. 4A) Unused dosing outputs
Monitoring functions	Flow rate in measurement water circuit Pressure Switch (optional) pH level Disinfection Level
Optional Extras	3 slots for optional modules
Signal current outputs	Up to 8 x 4 – 20 mA (option)
Alarm relay	Max. 4 A (230V~ or potential-free)
Interfaces	LAN (RJ45) 100 Mbit/s (at least CAT5 cable), USB, CAN, SD card slot; PM5-4 Relay, 4 universal relays (option)
Communication	Embedded web server and web-based graphical user interface
Electrical connection	100 – 240 V~, 50/60 Hz
Temperature ranges	Operating temperature 0 °C – 50 °C Storage temperature -20 °C + 70 °C
Protection class of controller	IP 65
Protection class of pump housing	IP 65
Dimensions (WxHxD)	715 x 495 x 125 mm
Humidity	0 - 90%, non-condensing
Control panel size (mm)	W 266 x H 363 x D 167

ASSOCIATED PRODUCTS

			
Flockmatic Vario with adjustable dosing qty switch	PM5 BMS	PM5 Extension Plug-in 4 Relay Board	Total Chlorine Module
127480		174120	127110
£ 465.79	£ 709.56	£ 285.00	£2, 917
			
Elatron DLX Pumps	Bayrol pH-Minus liquid 14.9%	Sodium Hypochlorite 14/15%	25l Bund Tank
Page - 117	5594328	SPL-SH020	HFK-A81
	£ 50.96	£ 34.00	£ 135.00

PoolManager®

- + Secure water treatment.
- + An audible alarm function is activated in the event of fluctuations exceeding the limit values. It can also send an e-mail in the event of an alarm.
- + Direct help.
- + A help hot key is visible at all times and when pressed displays relevant help text, regardless of the menu point you are using.
- + Precise measurement.
- + PoolManager measures the redox potential. PoolManager PRO uses the potentiostatic principle to precisely measure the actual chlorine content in the pool water and displays the chlorine value in mg/l.
- + Simple maintenance.
- + The method of free chlorine measurement used by PoolManager PRO is low maintenance, self-cleaning and durable.
- + Remote access to the system.
- + PoolManager connects to the internet with LAN connection enabling the monitoring and regulation of all functions a pool remotely using a phone, tablet or other internet enabled device.



	PoolManager® pH & Redox	PoolManager® pH & Bromine/ Chlorine Tablets	PoolManager® pH & O2	PoolManager® PRO pH & free chlorine
PRODUCT CODE - E				
Standard model	177111	177200	177300	177631
	£ 4,516	£ 4,516	£ 4,516	£ 6,433

DESCRIPTION

The PoolManager® is a true pool management system. It not only performs automatic water maintenance through continuous measurement, control and dosing of pH and disinfection, but also controls a variety of pool components such as heating, circulation pump, lighting, water attractions etc.

In addition to the precise and reliable water treatment of the pool, the PoolManager® can control various other functions of the pool such as the filter pump, the automatic cover, the pool heating or water attractions through its flexible programming option. Also underwater lights and even the garden lighting can be controlled via the PoolManager®.

The large, high-resolution touch screen allows easy reading of important information, as well as quick and intuitive navigation through the menu functions.

Once connected to the internet, PoolManager® can be accessed from any device (PC, smartphone or tablet).

The PoolManager® offers through its functionality the possibility to actively contribute to environmental protection. For example, it saves energy by reducing the power of the circulation pump during night operation, by actively controlling the solar heating or by using the power-saving «power down» function. It is also made largely from recyclable material.

Available in chlorine (redox), bromine (redox) and active oxygen versions. Developed and manufactured in Germany.

Caution: The installation and commissioning of the PoolManager® must be carried out by a trained professional installer!

Please read the unit's instruction manual carefully to familiarize yourself with its operation, paying particular attention to safety rules and instructions.

ASSOCIATED PRODUCTS

				
Bayrol pH-Minus liquid 45%	Bayrol pH-Minus liquid 14.9%	Sodium Hypochlorite 14/15%	25l Bund Tank	Saddle Clamps (4 Needed)
5594321	5594328	SPL-SH020	HFK-A81	Page - 118
£ 66.84	£ 50.96	£ 50.96	£ 135.00	



PoolRelax® Controller

+Advanced safety features are used to prevent overdosing of chemicals to pool water and watch over maximal hourly dose, rapid pH changes and maximal number of doses without response from the probe.

+ The Pool Relax ensures reliable and precise control of the set values relevant for optimal water treatment. The alarm function of the Pool Relax is activated in the event of fluctuations relating to the set values, or empty product containers, with acoustic and visual signals on the device.

+ Simple operation. All relevant functions are intuitive and can be set conveniently using the touchscreen. The large four line display is clear and easy to read.

+ The use of high quality components combined with a sophisticated technical design ensures the Pool Relax carries out tasks reliably without disruption.



	PoolRelax® pH & Redox	PoolRelax® pH & Bromine	PoolRelax® pH & Oxygen
PRODUCT CODE - E			
Standard model	193102	193200	193300
	£ 3,095	£ 3,095	£ 3,095

DESCRIPTION

PoolRelax® is an automatic dosing system for pH regulation and disinfection with chlorine, active oxygen or bromine. Through the use of high-quality components and a well thought-out technical design, the PoolRelax® performs its tasks reliably and safely.

A single touch on the screen is all you need to access the individual menu items or change a setting. All the relevant data is displayed in clear text and can be registered at a glance.

The menu can be displayed in the following languages: German, English, French, Spanish, Italian, Polish, Greek, Russian, Flemish, Slovakian, Latvian, Danish, Swedish, Hungarian, Portuguese and Croatian. The menu is well-structured and the system is easy to use and to understand.

Each menu item is also provided with context-related, meaningful help texts. Combined with its robust design, this means high functionality and the greatest possible reliability.

ASSOCIATED PRODUCTS

Bayrol pH-Minus liquid 45%	Bayrol pH-Minus liquid 14.9%	Sodium Hypochlorite 14/15%	Web Module for Pool Relax 3
5594321	5594328	SPL-SH020	174934
£ 66.84	£ 50.96	£ 34.00	£ 590.00



Dosing Pumps - Flockmatic





- + High quality peristaltic pump
- + Designed for dosing liquid flocculant
- + Wall and foot mounted versions
- + Variable flow from 2.5 to 600 ml/hr
- + Suction nozzle and injection valve included
- + Compatible with all BAYROL controllers
- + Adjustable flow rate



	BAYROL Flockmatic	BAYROL Flockmatic Vario
PRODUCT CODE - E	127420	127480
Standard model	£ 889	£ 1,083

DESCRIPTION		
Dosing Rate	0.01 l/h (10 ml/h)	Up to 600 ml/h
Electrical Supply	230v/50hz	230v/50hz
Max water temperature	45 degrees C	45 degrees C
Protection	IP65	IP 65
Maximum pressure	1.5 bar	3.0 bar
Dimensions	93 x 150 x 130 mm	93 x 150 x 130 mm

ASSOCIATED PRODUCTS

			
BAYROL Quickfloc Automatic Plus	Compact Controller	Pool Manager PRO	Analyt Controller
4195129	176999	177631	177800/177600
£ 74.96	Page 111	Page 114	Page 112



Dosing Pumps



- + Reliable solenoid pumps
- + Analogue and Digital versions
- + Wall and foot mounted versions
- + 0 - 100% proportional dosing
- + 1 l/hr upto 20 l/hr+
- + Compatible with all BAYROL controllers
- + Level Alarm (optional on analogue version)



	DLX MA/AD 1 l/hr Analogue wall mounted	DLX MA/AD 5 l/hr Analogue wall mounted	DLX MA/AD 8 l/hr Analogue wall mounted	DLX MA/AD 15 l/hr Analogue wall mounted
PRODUCT CODE - H				
Standard model	PLX232225E	PLX230385E	PLX232285E	PLX232315E
	£ 388	£ 395	£ 489	£ 527

	DLX B MA/AD 1 l/hr Analogue foot mounted	DLX B MA/AD 5 l/hr Analogue foot mounted	DLX B MA/AD 8 l/hr Analogue foot mounted	DLX B MA/AD 15 l/hr Analogue foot mounted
PRODUCT CODE - H				
Standard model	PBX232225E	PBX230385E	PBX232285E	PBX232315E
	£ 402	£ 414	£ 506	£ 546

	DLX MF/M 1 l/hr Digital wall mounted	DLX MF/M 5 l/hr Digital wall mounted	DLX MF/M 8 l/hr Digital wall mounted	DLX MF/M 15 l/hr Digital wall mounted
PRODUCT CODE - H				
Standard model	PLX172225E	PLX170385E	PLX172285E	PLX172315E
	£ 631	£ 631	£ 680	£ 726

	DLX B MF/M 1 l/hr Digital foot mounted	DLX B MF/M 5 l/hr Digital foot mounted	DLX B MF/M 8 l/hr Digital foot mounted	DLX B MF/M 15 l/hr Digital foot mounted
PRODUCT CODE - H				
Standard model	PBX1722253	PBX170385E	PBX172285E	PBX172315E
	£ 645	£ 649	£ 700	£ 743

ASSOCIATED PRODUCTS

Bayrol pH-Minus liquid 45%	Bayrol pH-Minus liquid 14.9%	Sodium Hypochlorite 14/15%	25l Bund Tank
5594321	5594328	SPL-SH020	HFK-A81
£ 66.84	£ 50.96	£ 50.96	£ 135.00

Dosing Accessories



Suction Lance 35cm	Suction Lance 60cm	Suction Lance 80cm
--------------------	--------------------	--------------------

PRODUCT CODE - H

Standard model	SSO0000805	SSO0000801	SSO0000802
	£ 179	£ 186	£ 186



50mm/1.5» Saddle Clamp	63mm/2» Saddle Clamp
------------------------	----------------------

PRODUCT CODE - H

Standard model	SADDLE15	SADDLE20
	£ 7.90	£ 9.00



AF Mixer PP 600mm	AF Mixer PP 1000mm	Manual Mixer PVC
-------------------	--------------------	------------------

PRODUCT CODE - H

Standard model	AGT1244003	AGT1244103	AGTM005101
	£ 1,018	£ 1,018	£ 204



Hand Transfer Pump

PRODUCT CODE - H

20014B036
£ 512



25L Dosing Tank	50L Dosing Tank	100L Dosing Tank	200L Dosing Tank	300L Dosing Tank
-----------------	-----------------	------------------	------------------	------------------

PRODUCT CODE - H

Standard model	HFK-A80	HFK-A82	HFK-A84	HFK-A86	HFK-A88
	£ 95	£ 135.50	£ 175.45	£ 185.15	£ 301.30



25L Bund Tank	50L Bund Tank	100L Bund Tank	200L Bund Tank	300L Bund Tank
---------------	---------------	----------------	----------------	----------------

PRODUCT CODE - H

Standard model	HFK-A81	HFK-A83	HFK-A85	HFK-A87	HFK-A89
	£ 135	£ 155.25	£ 185	£ 195	£ 315

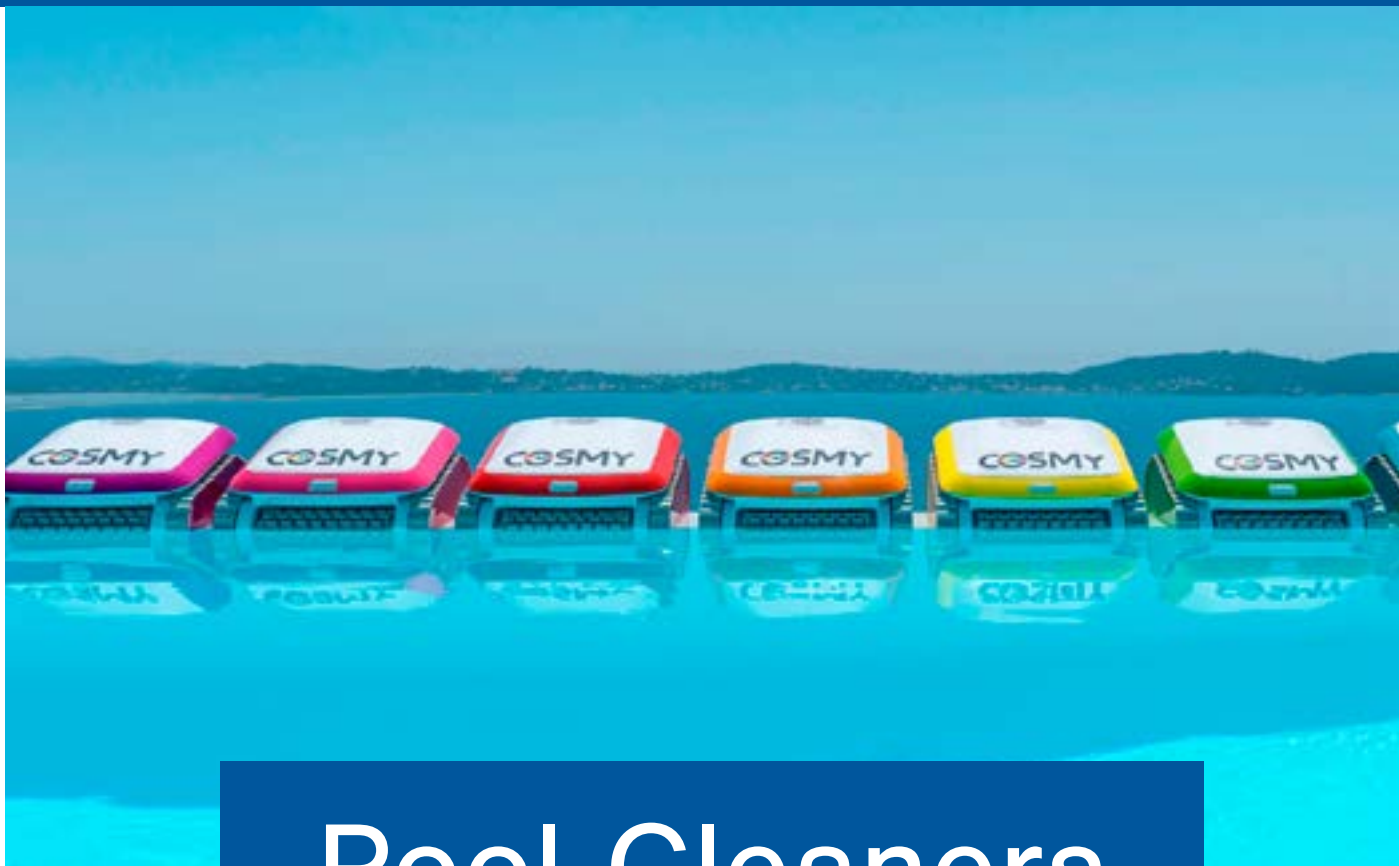

Pool Cleaners

AUTOMATIC CLEANERS	p.119	COMMERCIAL CLEANERS	p.129
ELECTRIC CLEANERS	p.120	• AQUARIUS	p.130
COMPARISON TABLE	p.122	• MAGNUM JUNIOR	p.130
DOMESTIC CLEANERS		• MAGNUM	p.130
COSMY		• ULTRAMAX JUNIOR	p.130
• Cosmy 150	p.124	• ULTRAMAX	p.130
• Cosmy 250	p.125	BATTERY CLEANERS	
P-SERIES		• PK Swift	p.132
• P450	p.126	• PK X-Flow	p.133
• P500 LED	p.127		
• P600 LED	p.128		

TWO EFFICIENT WAYS TO CLEAN A POOL FROM BWT

To clean a pool as well as possible, multiple parameters are considered in the choice of cleaning equipment: shape and lining of the pool, standard of cleaning, area to be covered, etc.

High technology BWT cleaners match the different features of a pool, the cleaning time and customer budget.

2 types of technologies are currently available:
Electric Cleaner and Battery Vacuum.

> ELECTRIC ROBOTIC CLEANERS: A HIGH-PERFORMANCE, STAND-ALONE SYSTEM

Separate from the filtration system and simply connected to the mains power, they are Plug & Play stand-alone equipment.

Easy to use and programmable (cleaning time, area to be covered, etc.), they reach every corner of the pool, climb the walls, clean the water line and collect impurities in their own filter basket.

There are different models for all types of pools.



> BWT RECHARGABLE BATTERY VACUUM: A SIMPLE AND AFFORDABLE SOLUTION

Rechargeable battery vacuum cleaners from BWT are the affordable solution to easy pool cleaning.

Vacuum cleaners capture debris by suction and accumulate it in the built in basket.

More affordable than electric cleaners, battery vacuum cleaners attach to the pool cleaning pole and are manually guided around the pool. independent of the filtration system, vacuums protect the pool filtration system from the dirt in the pool. Perfect for both in-ground and above-ground pools.

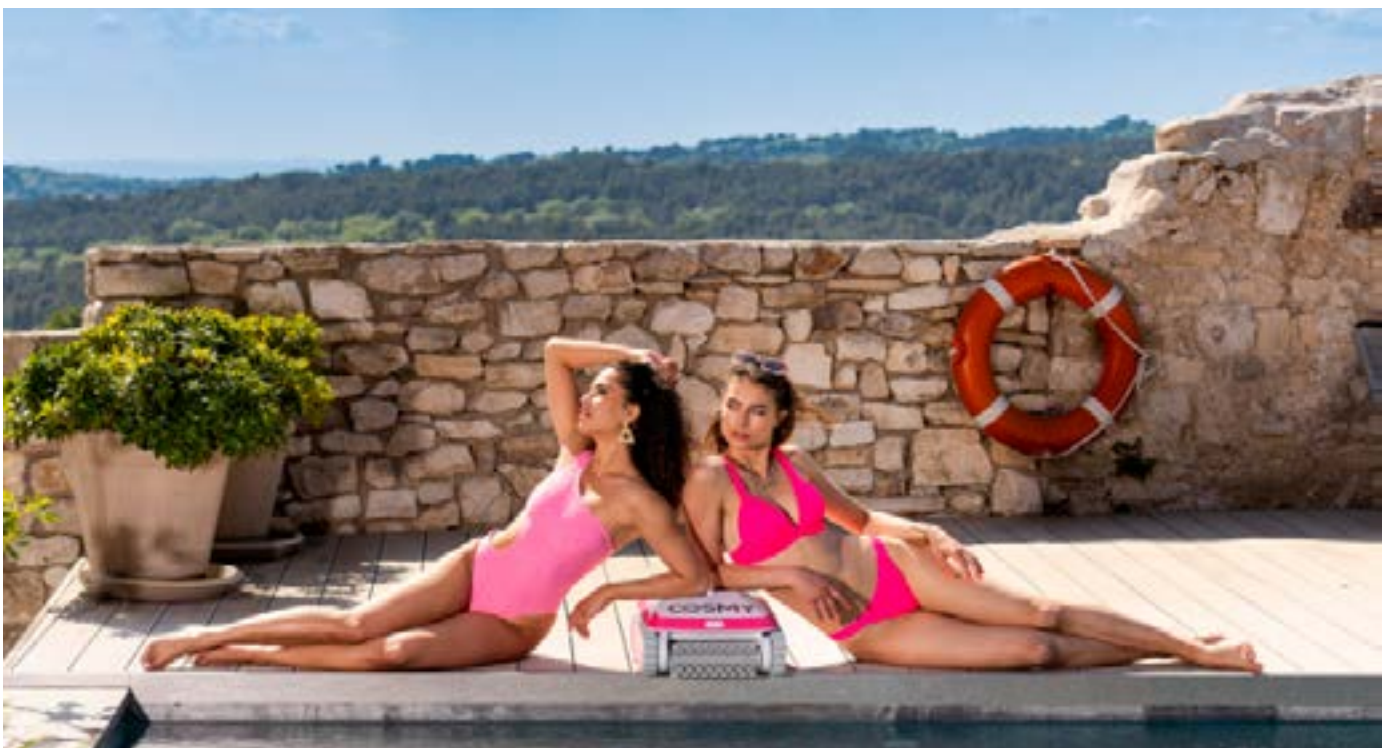

ELECTRIC POOL CLEANERS

A stand-alone and efficient solution



The electric robotic cleaner range from BWT is a complete offering for all pools.

Thanks to the embedded patented technology, the cleaning performance is maintained throughout the cleaning cycle. They even capture the finest debris without clogging the filter.

Separate from the filtration system, these Plug & Play devices trap debris in their own filter basket, making them stand-alone.

> COSMY THE BOT, ULTRA-CLEAN STYLE



Cosmy opens the path to a whole new world, where efficiency meets style and elegance, where size gives way to precision and intelligence.

Cosmy robots are equipped with two stage planetary gear technology, a drive system that offers greater efficiency and better precision; combined up to two drive motors and a powerful pump, Cosmy is one of the most reliable robotic cleaners on the market.

> P-LINE, POWERFUL AND EFFICIENT



P-Line robotic cleaners feature the most powerful suction of any robot on the market, it can be up to twice as strong thanks notably to its height adjustable nozzles. The closer they are to the surface being vacuumed, the more powerful the suction. Suction can be adjusted to efficiently capture the type of debris to be picked up. Thus, close to a beach for example, the nozzles can be set down low to effortlessly remove every grain of sand, thoroughly cleaning of all areas of the pool.





> AQUABOT - COMMERCIAL CLEANERS



Aquabot commercial robotic pool cleaners stand-alone. They minimize downtime thanks to our smart navigation algorithm which calculates the optimum cleaning route with every use. Combined with market-leading suction technology and advanced water filtration system, cleaning is quick and efficient ensuring a safe and hygienic swimming environment.

ELECTRIC CLEANERS - DOMESTIC

A stand-alone and efficient solution

COMPARATIVE TABLE OF RANGES TECHNICAL SPECIFICATIONS		Cosmy 150	Cosmy 250	P 450	P 500 LED	P 600 LED
						
Types of pools	Surfaces	Liner, polyester hull, reinforced PVC, painted concrete, Tiles	Tiles, liner, polyester hull, reinforced PVC, painted concrete	Tiles, liner, polyester hull, reinforced PVC, painted concrete	Tiles, liner, polyester hull, reinforced PVC, painted concrete	Tiles, liner, polyester hull, reinforced PVC, painted concrete
	Shapes	Rectangular, oval, free shape	Rectangular, oval, free shape	Rectangular, oval, free shape	Rectangular, oval, free shape	Rectangular, oval, free shape
	Bottom	Flat, gentle slope, composite slope	Flat, gentle slope, composite slope, diamond shape	Flat, gentle slope, composite slope, diamond shape	Flat, gentle slope, composite slope, diamond shape	Flat, gentle slope, composite slope, diamond shape
	Pool Size	8 m (16m cable)	12 m (18m cable)	12 m (18m cable)	12 m (18m cable)	15 m (23m cable)
Performance	Traction	Tracks - 1 motor	Tracks - 2 motors	Tracks - 2 motors	Tracks - 2 motors	Tracks - 2 motors
	Cleaning areas	Floor / walls / waterline	Floor / walls / waterline	Floor / walls / waterline	Floor / walls / waterline	Floor / walls / waterline
	Filtering level	Single	Dual Layer	Dual Layer	4D Hyperfine	4D Hyperfine
	Swivel	-	-	-	Yes	Yes
	Smart Navigation	Yes	Yes	Yes	Yes	Yes
	Remote control	-	✓ via the app	✓ via the app	-	✓ via the app
	Type of brush	PVC	PVC	PVC	PVA	PVA
Cycles	Number of cycles	3	3	3	2	3
	Cleaning cycles	Floor / walls / waterline	Floor / walls / waterline	Floor / walls / waterline	Floor / walls / waterline	Floor / walls / waterline
	Manual cleaning time adjustment	Yes	Yes	Yes	Yes	Yes
Ease of use	Full filter indicator	Yes	Yes	Yes	Yes	Yes
	Transparent window	-	-	-	✓	✓
	Illuminated filter	-	-	-	✓	✓
	Type of filter	Rigid Filter canister / Top access	Rigid Filter canister / Top access	Rigid Filter canister / Top access	Rigid Filter canister / Top access	Rigid Filter canister / Top access
	Trolley	-	✓	-	✓	✓
Warranty	2 years	3 years	3 years	4 years	4 years	

> ELECTRIC CLEANERS - COMMERCIAL

	Aquarius	Magnum Junior	Magnum	Ultramax Junior	Unltramax
					
POOL SIZE	For commercial pools up to 20 m long, any shape any surface finish	For small commercial pools up to 25 m long, all shapes and surface finishes	For small commercial pools up to 30 m long, all shapes and surface finishes	For semi-olympic pools up to 35 m long, all shapes and surface finishes	For olympic pools up to 50 m long, all shapes and surface finishes
CLEANING TYPE	Floor and walls	Floor and walls	Floor and walls	Floor	Floor
DURATION OF THE CLEANING CYCLE	3 hours, 4 hours or 5 hours	3 hours, 4 hours or 5 hours	3 hours, 4 hours or 5 hours	3 hours, 4 hours or 6 hours	3 hours, 4 hours or 6 hours
FILTER TYPE	4D, hyperfine microfibre, 1 XL bag	4D, hyperfine microfibre, 1 XL bag	4D, hyperfine microfibre, 1 XL bag	4D, hyperfine microfibre, 1 XL bag	4D, hyperfine microfibre, 1 XL bag
FILTER ACCESS	Easy bottom access	Easy bottom access	Easy bottom access	Easy bottom access	Easy bottom access
FULL FILTER INDICATOR	✓	✓	✓	-	-
BRUSH TYPE	4 PVA brush wheels	4 PVA brush wheels	4 PVA brush wheels	4 PVA brush wheels	4 PVA brush wheels
POWER SUPPLY	230 V/180W	230 V/180W	230 V/180W	230 V/180W	230 V/180W
NAVIGATION SYSTEM	Aqua Smart System	Aqua Smart System	Aqua Smart System	Aqua Smart System	Aqua Smart System
PLATFORM	2 Drive motors and a pump	2 Drive motors and a pump	2 Drive motors and a pump	2 Drive motors and 2 pumps	2 Drive motors and 2 pumps
SUCTION FLOW RATE	19 m3/h	19 m3/h	19 m3/h	38 m3/h	38 m3/h
CABLE LENGTH	23 m	30 m	36 m	36 m	45 m
ANTI-TANGLE SWIVEL	✓	✓	✓	✓	✓
COMPATIBLE WITH AN EXTERNAL TIMERS	✓	✓	✓	-	-
REMOTE CONTROL	✓	✓	✓	✓	✓
DIMENSIONS (L X W X H)	39 x 44,5 x 27 cm	39 x 53 x 26 cm	39 x 53 x 26 cm	40 x 54 x 31,5 cm	40 x 81 x 29 cm
STORAGE ACCESSORY	Caddy	Caddy	Caddy	Caddy	Caddy
WARRANTY	3 years	3 years	3 years	2 years	2 years



COSMY 150

2 YEAR
WARRANTY

EFFICIENCY, PURE AND SIMPLE

- + Responsive and Intuitive
- + Lightweight for effortless handling
- + Practical, clever design
- + Single Filtration
- + Surefooted on every surface



PRODUCT CODE - G

Product reference: 125505480

£ 899

FOR WHICH TYPE OF POOLS?

Types of pools	Private in-ground pools and above-ground pools with rigid walls, maximum 8 m
Pool shapes	Rectangular, oval, free shape
All Floors	Flat, gentle slope, composite slope
Pool surfaces	Liner, polyester hull, reinforced PVC, painted concrete, tiles

DESCRIPTION

Cleaning areas	Floor / Walls / Waterline
Number / Length of cleaning cycles	1 cycle - Floor / walls : 1h30
Power supply	Autonomous, connected to 230V mains supply before the transformer
Steering	Pre-programmed
Drive system	Tracks
Transmission	Gear transmission
Brushes	Yes
Filtration system / access	Rigid filter canister with access over the cleaner

TECHNICAL SPECIFICATIONS

Number of motors	1
Control box supply	100-240 VAC : 50 / 60 Hz
Power supply	29 VDC
Operating power	150 W
Cable length	16m
Cleaner size (L x W x H)	39 x 36.5 x 20 cm
Cleaner weight	5.75 kg

OPTIONAL ACCESSORIES (NOT INCLUDED)

	Flamingo colour kit	Cobalt colour kit	Apricot colour kit	Cherry colour kit	Lemon colour kit	Apple colour kit
Reference	125505969	125505970	125505972	125505973	125506059	125506060
ex VAT Price	£ 68	£ 68	£ 68	£ 68	£ 68	£ 68



COSMY 250

EFFICIENCY, PURE AND SIMPLE

- + Responsive and Intuitive
- + Smartphone APP
- + Caddy Included
- + Lightweight for effortless handling
- + Practical, clever design
- + Double Layer Filtration



4 YEAR WARRANTY*



PRODUCT CODE - G

Product reference: 125505482

£ 1,250

FOR WHICH TYPE OF POOLS?

Types of pools	Private in-ground pools and above-ground pools with rigid walls, maximum 12 m
Pool shapes	Rectangular, oval, free shape
All Floors	Flat, gentle slope, composite slope
Pool surfaces	Liner, polyester hull, reinforced PVC, painted concrete, tiles

DESCRIPTION		TECHNICAL SPECIFICATIONS	
Cleaning areas	Floor / Walls / Waterline	Number of motors	2
Number / Length of cleaning cycles	1 cycle - Floor / walls : 1h30	Control box supply	100-240 VAC : 50 / 60 Hz
Power supply	Autonomous, connected to 230V mains supply before the transformer	Power supply	29 VDC
Steering	Pre-programmed	Operating power	150 W
Drive system	Tracks	Cable length	18m
Transmission	Gear transmission	Cleaner size (L x W x H)	39 x 36.5 x 20 cm
Brushes	Yes	Cleaner weight	5.75 kg
Filtration system / access	Rigid filter canister with access over the cleaner		

OPTIONAL ACCESSORIES (NOT INCLUDED)

	Flamingo colour kit	Cobalt colour kit	Apricot colour kit	Cherry colour kit	Lemon colour kit	Apple colour kit
Reference	125505969	125505970	125505972	125505973	125506059	125506060
ex VAT Price	£ 68	£ 68	£ 68	£ 68	£ 68	£ 68



P 450

EFFICIENCY, PURE AND SIMPLE

- + Responsive and Intuitive
- + Smartphone APP with Premium Features
- + Battery Ready
- + Lightweight for effortless handling
- + Practical, clever design
- + Double Layer Filtration
- + Surefooted on every surface



PRODUCT CODE - E

£ 1,550

FOR WHICH TYPE OF POOLS?

Types of pools	Private in-ground pools and above-ground pools with rigid walls, maximum 12 m
Pool shapes	Rectangular, oval, free shape
All Floors	Flat, gentle slope, composite slope
Pool surfaces	Liner, polyester hull, reinforced PVC, painted concrete, tiles

DESCRIPTION

Cleaning areas	Floor / Walls / Waterline
Number / Length of cleaning cycles	1 cycle - Floor / walls : 1h30
Power supply	Autonomous, connected to 230V mains supply before the transformer
Steering	Pre-programmed
Drive system	Tracks
Transmission	Gear transmission
Brushes	Yes
Filtration system / access	Rigid filter canister with access over the cleaner

TECHNICAL SPECIFICATIONS

Number of motors	2
Control box supply	100-240 VAC : 50 / 60 Hz
Power supply	29 VDC
Operating power	150 W
Cable length	18m
Cleaner size (L x W x H)	39 x 36.5 x 20 cm
Cleaner weight	5.75 kg





P500+ LED

EFFICIENCY, PURE AND SIMPLE

- + Gyroscope
- + Anti-tangle swivel
- + Bi-directional suction
- + 4D Hyperfine Filtration
- + Ultimate power technology



4 YEAR
WARRANTY*



PRODUCT CODE - E

Product reference: 125576421

£ 1,850

FOR WHICH TYPE OF POOLS?

Types of pools	Private in-ground pools and above-ground pools with rigid walls, maximum 12 m
Pool shapes	Rectangular, oval, free shape
All Floors	Flat, gentle slope, composite slope
Pool surfaces	Liner, polyester hull, reinforced PVC, painted concrete, tiles

DESCRIPTION		TECHNICAL SPECIFICATIONS	
Cleaning areas	Floor / Walls / Waterline	Number of motors	2
Number / Length of cleaning cycles	1 cycle - Floor / walls /W waterline - 2.0hrs	Control box supply	100-240 VAC : 50 / 60 Hz
Power supply	Autonomous, connected to 230V mains supply before the transformer	Power supply	29 VDC
Steering	Pre-programmed	Operating power	180 W
Drive system	Tracks	Cable length	18m
Transmission	Gear transmission	Cleaner size (L x W x H)	39.1 x 43 x 23.4 cm
Brushes	Yes	Cleaner weight	11 kg
Filtration system / access	Rigid filter canister with access over the cleaner		





P600+ LED

EFFICIENCY, PURE AND SIMPLE

- + Gyroscope
- + Anti-tangle swivel
- + Smartphone APP with Premium Features
- + Bidirectional suction
- + 4D Hyperfine Filtration
- + Ultimate power technology



4 YEAR
WARRANTY*



PRODUCT CODE - E

Product reference: 125305508

£ 2,150

FOR WHICH TYPE OF POOLS?

Types of pools	Private in-ground pools and above-ground pools with rigid walls, maximum 15 m
Pool shapes	Rectangular, oval, free shape
All Floors	Flat, gentle slope, composite slope
Pool surfaces	Liner, polyester hull, reinforced PVC, painted concrete, tiles

DESCRIPTION		TECHNICAL SPECIFICATIONS	
Cleaning areas	Floor / Walls / Waterline	Number of motors	2
Number / Length of cleaning cycles	1 cycle - Floor / walls /W waterline - 2.0hrs	Control box supply	100-240 VAC : 50 / 60 Hz
Power supply	Autonomous, connected to 230V mains supply before the transformer	Power supply	29 VDC
Steering	Pre-programmed	Operating power	180 W
Drive system	Tracks	Cable length	23m
Transmission	Gear transmission	Cleaner size (L x W x H)	39.1 x 43 x 23.4 cm
Brushes	Yes	Cleaner weight	11 kg
Filtration system / access	Rigid filter canister with access over the cleaner		





Water quality is as important to us as it is to you. We've spent decades developing water purification technology that delivers the highest standard of clean water, whilst remaining affordable and respectful of the environment. As a result, operators can trust that our robotic pool cleaners will leave your swimming pools spotless. Our smart navigation algorithm calculates the optimum cleaning route with every use. Combined with our market-leading suction technology and advanced water filtration system, cleaning is quick and efficient to ensure a safe and hygienic swimming environment.



> AQUARIUS LINE

- Cleans in-ground commercial pools of all shapes and sizes
- Cleans floor, walls and waterline
- Low operating cost per hour
- Unmatched suction power for optimal cleaning
- Smart navigation algorithm for fast and efficient cleaning
- Compatible with all pool finishes
- User-friendly operation
- Auto shut-off at end of cleaning cycle
- Premium trolley for easy transport
- The filter can be accessed from the top so it can be rinsed without touching the debris.



> MAGNUM LINE

- Cleans in-ground commercial pools of all shapes and sizes
- Cleans floor, walls and waterline
- Low operating cost per hour
- Unmatched suction power for optimal cleaning
- Smart navigation algorithm for fast and efficient cleaning
- Compatible with all pool finishes
- User-friendly operation
- Auto shut-off at end of cleaning cycle
- Premium trolley for easy transport
- The filter can be accessed from the top so it can be rinsed without touching the debris.



> ULTRAMAX LINE

- Cleans in-ground commercial pools of all shapes and sizes
- Cleans floor, walls and waterline
- Low operating cost per hour
- Unmatched suction power for optimal cleaning
- Smart navigation algorithm for fast and efficient cleaning
- Compatible with all pool finishes
- User-friendly operation
- Auto shut-off at end of cleaning cycle
- Premium trolley for easy transport
- The filter can be accessed from the top so it can be rinsed without touching the debris.



Aquarius

PRODUCT CODE - G

Standard model	125258752
----------------	-----------

£ 2,995



Magnum Junior

PRODUCT CODE - G

Standard model	125258753
----------------	-----------

£ 3,995



Magnum

PRODUCT CODE - G

Standard model	125258754
----------------	-----------

£ 4,995



Ultramax Junior

PRODUCT CODE - G

Standard model	125258755
----------------	-----------

£ 7,995



Ultramax

PRODUCT CODE - G

Standard model	125258756
----------------	-----------

£ 9,995



AQUABOT Commercial Cleaners

	Aquarius	Magnum Junior	Magnum	Ultramax Junior	Unltramax
					
POOL SIZE	For commercial pools up to 20 m long, any shape any surface finish	For small commercial pools up to 25 m long, all shapes and surface finishes	For small commercial pools up to 30 m long, all shapes and surface finishes	For semi-olympic pools up to 35 m long, all shapes and surface finishes	For olympic pools up to 50 m long, all shapes and surface finishes
CLEANING TYPE	Floor and walls	Floor and walls	Floor and walls	Floor	Floor
DURATION OF THE CLEANING CYCLE	3 hours, 4 hours or 5 hours	3 hours, 4 hours or 5 hours	3 hours, 4 hours or 5 hours	3 hours, 4 hours or 6 hours	3 hours, 4 hours or 6 hours
FILTER TYPE	4D, hyperfine microfibre, 1 XL bag	4D, hyperfine microfibre, 1 XL bag	4D, hyperfine microfibre, 1 XL bag	4D, hyperfine microfibre, 1 XL bag	4D, hyperfine microfibre, 1 XL bag
FILTER ACCESS	Easy bottom access	Easy bottom access	Easy bottom access	Easy bottom access	Easy bottom access
FULL FILTER INDICATOR	✓	✓	✓	-	-
BRUSH TYPE	4 PVA brush wheels	4 PVA brush wheels	4 PVA brush wheels	4 PVA brush wheels	4 PVA brush wheels
POWER SUPPLY	230 V/180W	230 V/180W	230 V/180W	230 V/180W	230 V/180W
NAVIGATION SYSTEM	Aqua Smart System	Aqua Smart System	Aqua Smart System	Aqua Smart System	Aqua Smart System
PLATFORM	2 Drive motors and a pump	2 Drive motors and a pump	2 Drive motors and a pump	2 Drive motors and a pump	2 Drive motors and a pump
SUCTION FLOW RATE	19 m3/h	19 m3/h	19 m3/h	38 m3/h	38 m3/h
CABLE LENGTH	23 m	30 m	36 m	36 m	45 m
ANTI-TANGLE SWIVEL	✓	✓	✓	✓	✓
COMPATIBLE WITH AN EXTERNAL TIMERS	✓	✓	✓	-	-
REMOTE CONTROL	✓	✓	✓	✓	✓
DIMENSIONS (L X W X H)	39 x 44,5 x 27 cm	39 x 53 x 26 cm	39 x 53 x 26 cm	40 x 54 x 31,5 cm	40 x 81 x 29 cm
STORAGE ACCESSORY	Caddy	Caddy	Caddy	Caddy	Caddy
GUARANTEE	3 years	3 years	3 years	3 years	3 years



PRO PK SWIFT

BATTERY POWERED VACUUM

- + Compatible with above-ground and in-ground pools.
- + Cordless and transportable.
- + Rechargeable Lithium battery.
- + High suction power
- + Patented dual filtration system.
- + Hand grip facilitates removal of debris.
- + Connects to a telescopic pole (pole not included).



2 YEAR
WARRANTY



PRODUCT CODE - G

Product reference : 125503677

£ 249

FOR WHICH TYPE OF POOLS?

Types of pools	Private in-ground pools and above-ground pools with rigid walls, maximum 10 x 5m
Pool shapes	Rectangular, oval, free shape
All Floors	Flat, gentle slope, composite slope, diamond shape
Pool surfaces	Tiles, liner, polyester hull, reinforced PVC, painted concrete

TECHNICAL SPECIFICATIONS

Rapidly vacuums up debris in mid sized pools.
Fast, efficient cleaning.
Picks up leaves and fine debris.
Unique design for improved suction.
Extra-large debris canister.
Magnetic switch to ensure absolute water tightness.
Features a quick drain system.
A storage bag is included.
Inlet suction size



PRO PK X-FLOW

BATTERY POWERED VACUUM

- + Compatible with above-ground and in-ground pools.
- + Cordless and transportable.
- + Rechargeable Lithium battery.
- + Fine mesh filter bag.
- + Hand grip facilitates removal of debris.
- + Connects to a telescopic pole (pole not included).



2 YEAR
WARRANTY



PRODUCT CODE - G

Product reference : 125503678

£ 299

FOR WHICH TYPE OF POOLS?

Types of pools	Private in-ground pools and above-ground pools with rigid walls, maximum 12 x 6 m
Pool shapes	Rectangular, oval, free shape
All Floors	Flat, gentle slope, composite slope, diamond shape
Pool surfaces	Tiles, liner, polyester hull, reinforced PVC, painted concrete

TECHNICAL SPECIFICATIONS

Rapidly vacuums up debris in mid sized pools.

Fast, efficient cleaning.

Picks up leaves and fine debris.

Unique design for improved suction.

Extra-large debris canister.

Magnetic switch to ensure absolute water tightness.

Features a quick drain system.

A storage bag is included.

Inlet suction size





Pool Covers

HF POOL COVERS	p.135
• Tidal In-Pool Covers	p.136
• HF Slats	p.138
• The Wave	p.140
COVERSEAL	p.143
• Manual System	p.146
• Semi-Automatic System	p.147
• Automatic System	p.148

The Tidal Range of in-pool slatted covers

Designed and built in the UK, The HeatForm Tidal pool covers are a high end, slatted cover system engineered to the most exacting standard and designed with the highest quality components.

A decent quality slatted pool cover provides multiple benefits; reduced evaporation, additional thermal insulation and solar heat gains as well as reducing manual and chemical maintenance. We believe a cover is the icing on the cake of any pool project and as a prominent piece of kit, it should not only be efficient and robust but also look good. HeatForm slatted covers are modern and sleek in appearance and available in a variety of colours.

The in-ground cover system is available in the following installation options:



HF Tidal Letterbox with top support

In this configuration, the cover is concealed in a wet pit located behind a vanity wall. The top support is available for both wooden decking or stainless steel trays designed for patios. The cover system is accessible from the top to allow for easy maintenance and cleaning.

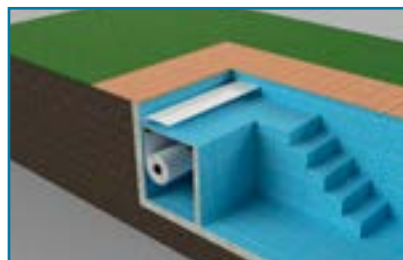

HF Tidal Beach Entry with PVC lid supports

This configuration allows for the submerged drive system to be installed when a purpose-built cover pit has not been designed into an existing or new pool. HeatForm covers modular design allows for a made-to-measure bench height. The cover panels can be lined to match your choice of pool liner.

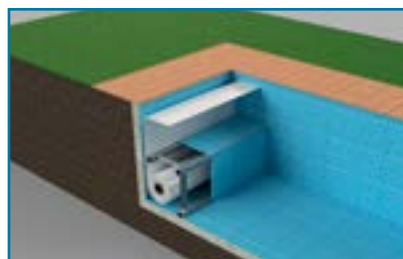

HF Tidal Bench system

This configuration allows for the submerged drive system to be installed in the bottom of the pool always retaining full access to the cover roller.

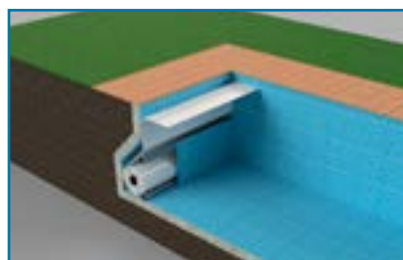

HF Tidal Cave Niche with PVC front wall

This configuration allows for the submerged drive system to be installed in the bottom of the pool in a niche built into the pool wall and retains full access to the cover roller via a front mounted PVC or composite panel which can be lined.

HEATFORM TIDAL IN-POOL COVERS

HF Tidal Pool Covers

[Contact Us for Quotes](#)

Versatility for shaped pools

HeatForm's slat profiles allow for easy manipulation to suit shaped pools and are ideal for using in conjunction with roman ends, in-built jacuzzis, retro-fitted counter current units or plunge pools.

Pools with in-built jacuzzis

If the pool has been designed with a jacuzzi or plunge pool, a HeatForm slatted cover can accommodate these either by covering the full pool and additional areas or by being shaped to fit around the additions.



Pools with recesses or cutouts

If the pool is recessed to allow for a set of steps or shaped to fit the area of install, HeatForm covers can accommodate these.



Pools with retro fit swim jets

Even the smallest cut out can be catered for, such as those with a retrospectively fitted counter-current system like the HeatForm Velocity unit.



Pools with shaped edges

Rounded edges or corners are easily achieved with the HeatForm cover systems, allowing use in a range of different shaped pools

The HF Tidal In-Ground Motor System

Following over 15 years of service in the field, the in-roller motor, used by HeatForm, has proven to be extremely reliable and efficient. With its clever use of nitrogen rather than resin to waterproof the mechanical components, it continues to be at the front of the market for innovation.

As the motor is fitted directly into the cover roller, there are no moving parts housed outside of the pool, ensuring minimum space requirements outside of the pool perimeter. The roller itself is immersed in the pool and supported by bracketry on both sides bolted to the pool structure. The cable from the motor passes through the pool shell and is covered in a plastic sleeve for additional protection.

The fully automated cover system is operated simply using a key switch or remote control. The motor comes in 250Nm and 500Nm torque variations, allowing for a wide range of pool sizes and depths and is provided with a five year manufacturer warranty.

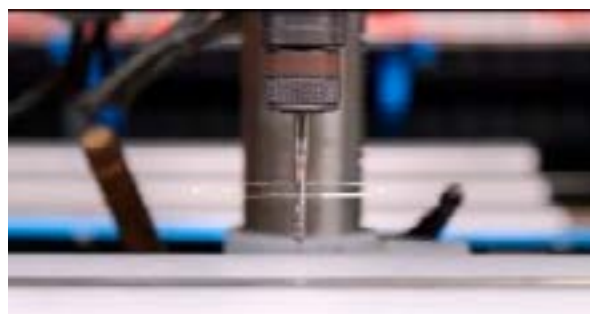

HeatForm Tidal Slats

The complete range of cover slats have been carefully selected by the team at HeatForm.

Available in both PVC and Polycarbonate, there are options to suit all tastes, budgets and applications.

HeatForm offers 2 different slat types, the standard profile 60 x 14mm with three closed air chambers and the premium profile 67.5 x 16.5mm with four closed air chambers. The standard profile is available in PVC and polycarbonate. The premium profile is available exclusively in PC solar and aluminum effect.

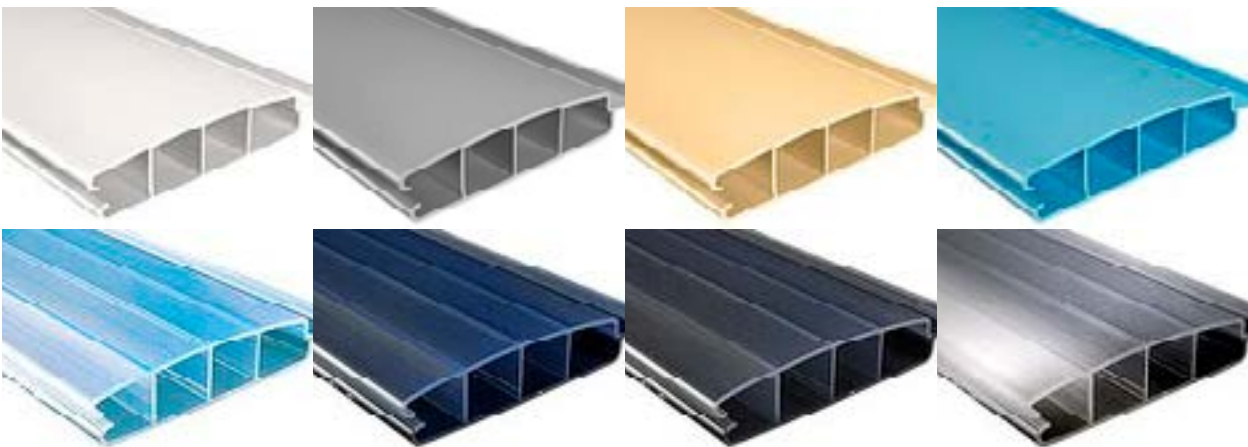

INSULATION VALUES OF THE HEATFORM SLATS:



- Standard profile 60x14mm : $U = 4.55 \text{ W/m}^2\text{K}$
- Standard profile 67.5x16.5mm : $U = 3.80 \text{ W/m}^2\text{K}$

Despite the waterproofness of a slat, condensation inside the profile is unavoidable and completely normal. Please be aware condensation is visible in slats with a transparent top layer.

HEATFORM TIDAL IN-POOL COVERS

HF Tidal Pool Covers

Contact Us for Quotes



- ◇ Solar and Electric versions
- ◇ Integrated LED lighting
- ◇ 4 x End stand colour options - Anthracite, Light Grey, Sand and White
- ◇ Wide range of slat colours
- ◇ Remote control as standard
- ◇ UK Designed and Manufactured - by HeatForm
- ◇ 3 year system warranty
- ◇ Made to measure

Get the pool party started with our playful above ground cover system!



White - Solar



Anthracite - Solar



Light Grey - Solar



Sand - Solar



White - Electric

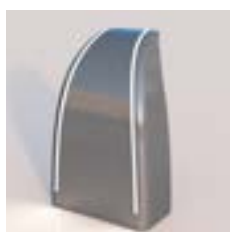

Anthracite - Electric



Light Grey - Electric



Sand - Electric

Wave End Stands

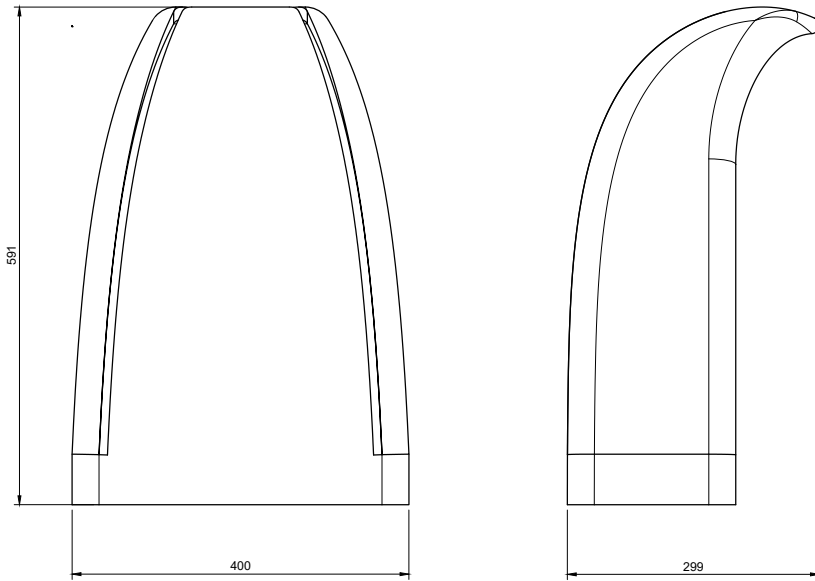

HeatForm Wave Slat Options



White PVC



Grey PVC



Beige PVC



Blue PVC

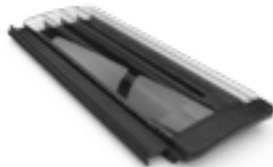

Solar PC



Alu PC



Blue PC - Premium

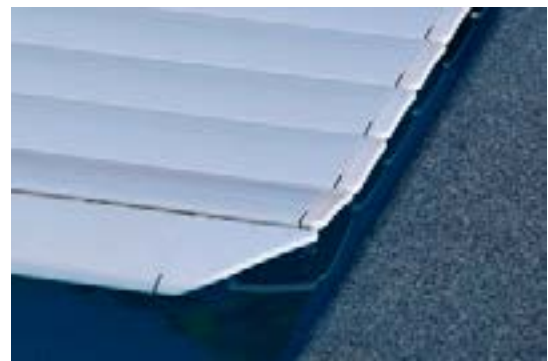
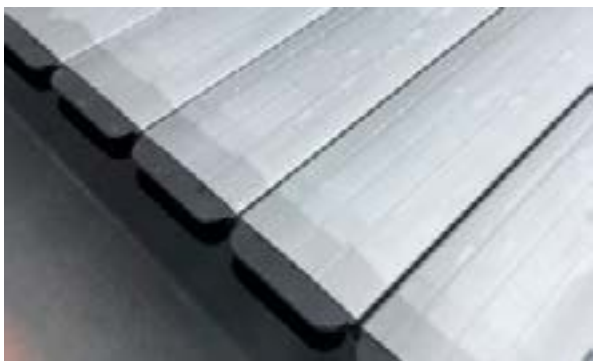

HEATFORM WAVE COVERS

HF Wave Pool Covers

Contact Us for Quotes



coverseal

The Coverseal System

The Coverseal brand was born out of a desire to bring both an aesthetic and a high-performing solution to a demanding clientele. Originating from the world of industry and more precisely, fast-opening flexible doors, this technology has been adapted to the specific, highly demanding swimming pool setting.

The membrane was developed by the brand Serge Ferrari, the world leader in this market, for top resistance to UV rays, extreme climatic conditions and the most exacting safety standards. It will remain perfectly taut right across the years, for impeccable aesthetics and unfailing security.

The exclusive, patented system comprises a unique mechanism that allows the membrane to unroll and lock in place courtesy of an extra-flat, extremely discreet, 10 mm thick rail.

The design stops the build-up of rain water traditionally seen on safety covers, thus removing the need for an unsightly cover pump. What's more, the rail holding the belt will never slip, or be a hazard for those walking over it, eliminating the risk of toes getting stuck.

The quality of the selected materials, especially for the membrane and the watertightness brought about by the patented locking system, guarantees clearer, cleaner water. Staying perfectly taut in all circumstances, the membrane stops leaves and debris falling into the pool, reducing the affects of photosynthesis and, as a consequence, the build-up of algae in the pool.

Available in three drive variations, manual, semi-automatic and fully automatic, the covers can be opened and closed in as little as one minute and cater for nearly any pool setting.



coverseal



The Coverseal System - The Technology

The patented Coverseal system comprises a unique mechanism that allows the fabric to unroll and lock in place thanks to an extra-flat, extremely discreet, 10 mm thick rail.

The fabric has been developed by the Serge Ferrari brand, the world leader in this market, to achieve top resistance to UV rays, extreme climatic conditions and the most exacting safety standards, particularly NF P90-308 of December 2013.

The great care given to selecting the materials used and an exclusive locking system enable the pool to be made safe effectively, regardless of the pool size and shape. The high resilience of the pre-stressed PVC membrane means that it will bear the weight of one or a number of people, particularly children and pets.

Energy costs and the desire to better safeguard the environment are additional reasons for choosing a Coverseal cover. During the day, the sun's rays will warm up the cover and the water in the pool courtesy of radiation transfer. The pool will therefore accumulate heat and help keep heating costs to a minimum. This will ensure immediate savings in both water and energy. During colder periods, the cover will also limit frost formation, providing better protection for the pool and its associated equipment.



coverseal

The Coverseal System - Manual



The “Manual” model is the ideal solution for pool owners who wish to make the most of all the advantages of a Coverseal on a tighter budget. Operated by one person courtesy of a ratchet key, it allows you to guarantee maximum safety for your loved ones but also to keep your water cleaner and warmer.

COVERSEAL MANUAL COVER SYSTEM

Cover system - Manual crank

[Contact Us for Quotes](#)

The Coverseal System - Semi-Automatic



The “Semi-Automatic” is characterised by a control unit equipped with batteries that can be charged on your domestic electrical supply within hours. Once this unit is charged, a couple of dozen opening/closing cycles are possible. Making your pool safe or uncovering it to enjoy it is effortless, taking less than one minute.

COVERSEAL SEMI-AUTOMATIC COVER SYSTEM

Cover system - semi-automatic
control unit

[Contact Us for Quotes](#)

The Coverseal System - Automatic



The “Automatic” model is the crown of the range, combining technology, aesthetics and respect for the environment. Activated by a wired or wireless control unit (with the pool kept in sight), it provides the optimum convenience and allow you to uncover or make your pool safe in less than one minute. This cover is chosen by demanding customers who refuse to compromise between aesthetics and performance.

COVERSEAL AUTOMATIC COVER SYSTEM

Cover system - Automatic
control unit

[Contact Us for Quotes](#)

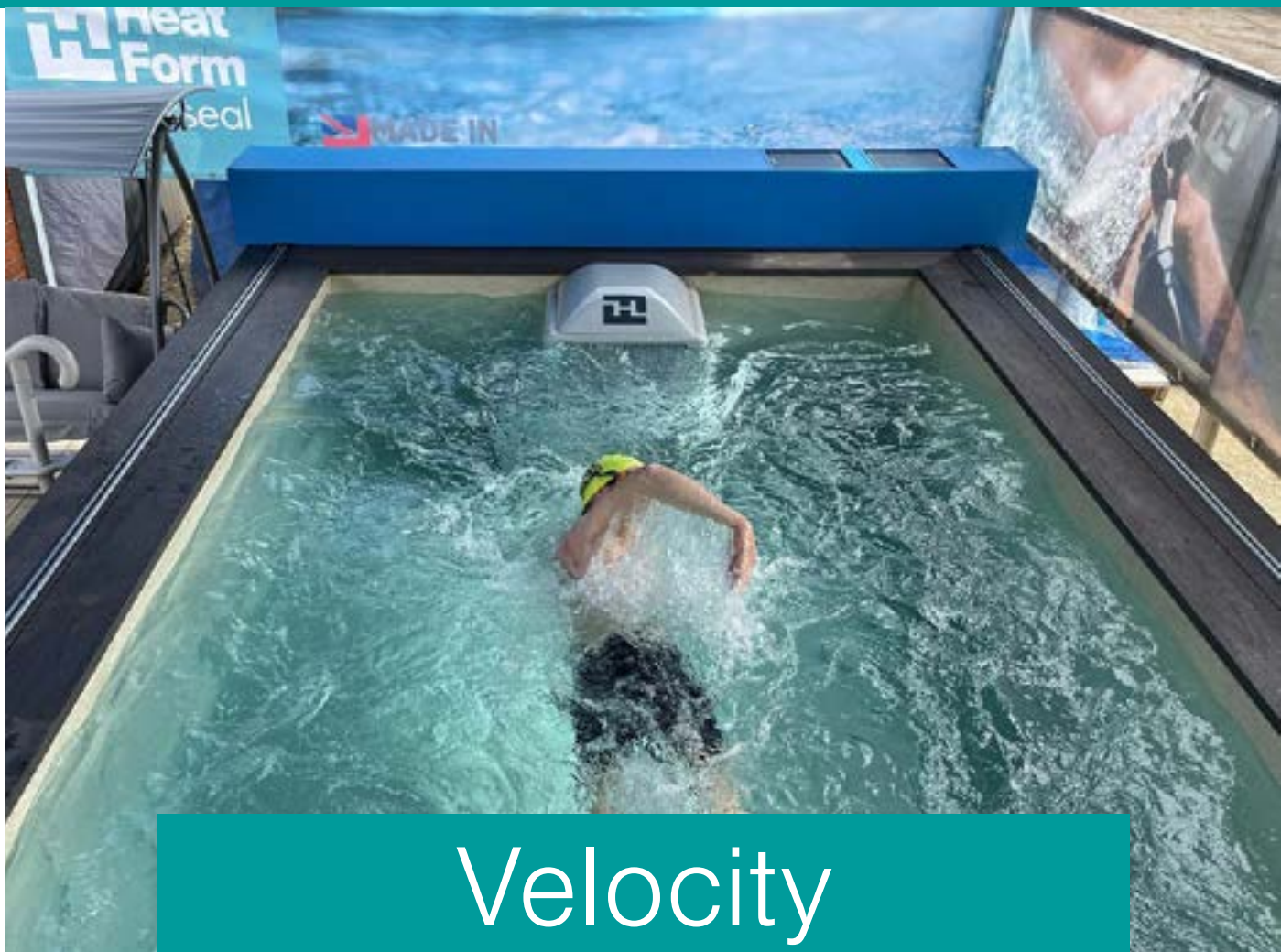

Velocity Swim Jet

INTRODUCTION

- Velocity p.151
- Velocity Swim App p.153
- Velocity Swim App p.155

Velocity Swim Jet by HeatForm

The Velocity Swim Jet is the next generation in counter-current swimming machines. Designed and manufactured in the UK by HeatForm, Velocity has been created after years of research and development to produce the most powerful and pleasant resistance-swimming experience.

Utilising hydraulic technology, the Velocity counter current is able to provide power to the pool unrivalled by any existing electric drive system. Working in partnership with cross-channel swimmers, triathletes and other swimming professionals, we have created the ultimate current-like and fully adjustable jet flow stream, suitable for all levels of ability.

By incorporating the latest patented inverter technology within the unit, the highest possible power and performance levels are incorporated, whilst reducing the running costs and noise traditionally seen with similar systems.

The Velocity Swim Jet is the first and only counter current manufactured in the UK, it is in keeping with the HeatForm philosophy of innovative products with a reduced carbon footprint: helping the environment and reducing the cost to the consumer.

Velocity Swim Jet - The System

At its heart, Velocity is powered by a 4kW/5hp inverter driven motor. The motor has been designed to utilise the latest in inverter drive technology, giving a fully variable and adjustable swimming experience.

By using a modern inverter system, the Velocity power pack regulates the speed of the motor to adjust the flow of biodegradable hydraulic oil to the main head unit. This is different to other, older systems which require the motor to run constantly at full speed.

What does this actually mean?

The result of using the inverter drive is a quieter, more cost-effective system which is much more suited to installation in a European domestic environment. Inverter technology means that the lower the motor speed, the lower the power consumption and increased saving to your electricity bill, a win for both the consumer and the environment. To make life easier, Velocity only requires a standard 25 amp single phase electrical supply to power the motor.

How powerful is the resultant water flow?

The Velocity power pack, installed within the pool plant room, provides over 100bar of hydraulic power to the unique head unit situated in the pool. A 42cm propeller developed in conjunction with the UK's finest powerboat designers generates a perfect flow. The water is then pushed and straightened through the custom designed HeatForm grid system, resulting in a swimming experience second to none.



Velocity Swim Jet - The Performance

The Velocity swim jet has been created with performance at the forefront. It has been tested extensively by swimmers of all abilities from children and casual dippers through to professional elite athletes. Whether you swim to compete, for pleasure or to just to stay fit, Velocity's easily adjustable flow rates enable everyone to jump in and lose themselves swimming against the current.

The flow of water at all speeds is smooth, wide and deep, giving the feel of your full body swimming in a river current, resulting in a more natural swimming experience than the more concentrated jet systems found in pump powered swim spas.

The speed is fully adjustable via either the main control box or the supplied splashproof remote control. It comes with pre-programmed levels, which can be adjusted to create the exact level of flow you require. The main drive system also has an in-built LED display showing your power at any given time, to assist with a consistent training programme.

The highest level of water flow achievable is 58 seconds for 100m, suitable for an elite swimmer.

Find out more at www.hf-velocity.com

Velocity Swim Jet

PRODUCT CODE - F		
	Velocity in Light Grey	Velocity in Anthracite Grey
Velocity Standard Complete	VEL-L/GREY	VEL-ANTH
Complete Velocity Swim Jet includes: Velocity head unit, power pack, remote control, biodegradable oil and installation kit. Available in single and three phase configurations	£ 8,750	£ 8,750
Velocity Hidden Complete	VEL-HIDD-L/GREY	VEL-HIDD-ANTH
Complete Velocity Swim Jet includes: Velocity head unit, power pack, remote control, biodegradable oil and installation kit. Available in single and three phase configurations	£ 8,750	£ 8,750
1.2m high x 2.0m wide PVC vanity panel	VEL-JPS12	
2m wide x 1.2m high PVC Vanity panel for use with Velocity hidden complete, supplied ready for lining with all fixings and stainless steel grilles	£ 1,752	
1.5m high x 2.0m wide PVC vanity panel	VEL-JPS15	
2m wide x 1.5m high PVC Vanity panel for use with Velocity hidden complete, supplied ready for lining with all fixings and stainless steel grilles	£ 1,971	
1.2m high x 2.0m wide Stainless Steel vanity panel	VEL-SS12	
2m wide x 1.2m high Stainless Steel Vanity panel for use with Velocity hidden complete, supplied with all fixings and stainless steel grilles	£ POA	
Over Wall Retro Fit Kit	VEL-RET-KIT	VEL-RET-KIT
Kit to fit Velocity to an existing pool without the need to fix to pool wall. Includes - Mounting bracket in stainless steel, special matching top cover cap and fixings	£ 748	£ 748

OPTIONAL ACCESSORIES (NOT INCLUDED)

Remote display pad (wired)

Optiport

£ 165



Colour matched top cap

Hidden mounting bracket

Composite housing
available in anthracite
grey or light grey

Propellor housing

42 cm propellor

Matching filter providing
safety protection without
restricting flow

Remote control

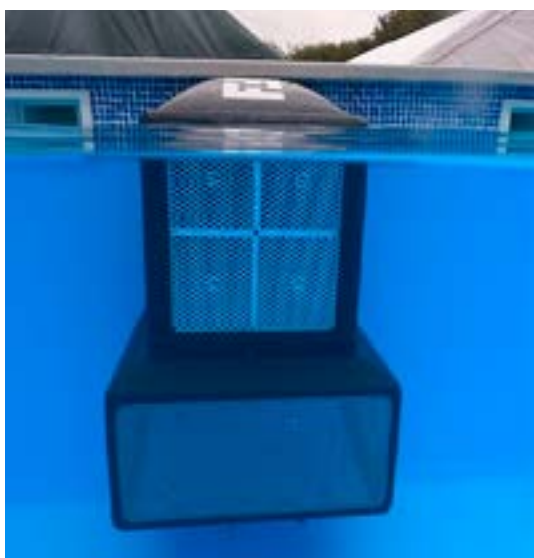

Standard Velocity

Find out more at www.hf-velocity.co.uk



Velocity hidden behind PVC panel.
Panel can be tiled or lined

Velocity SwimApp

The Velocity SwimApp provides the user with a visual timing screen and full speed adjustable programming option. The Velocity SwimApp offers a training tool for teachers, as well as a perfect monitoring tool for the end user to stay abreast of their exercise patterns.

With additional functionality allowing the control of other pool functions, the app provides an interactive interface that is easy and simple to use.

Precision control is possible through customisable swim programmes. The user can control the timing of each phase, the power the machine operates at and the number of cycles the program is used for.

With multiple swim programmes able to be loaded, the app provides the perfect tool for an early morning warm up swim, right through to an intensive training session.

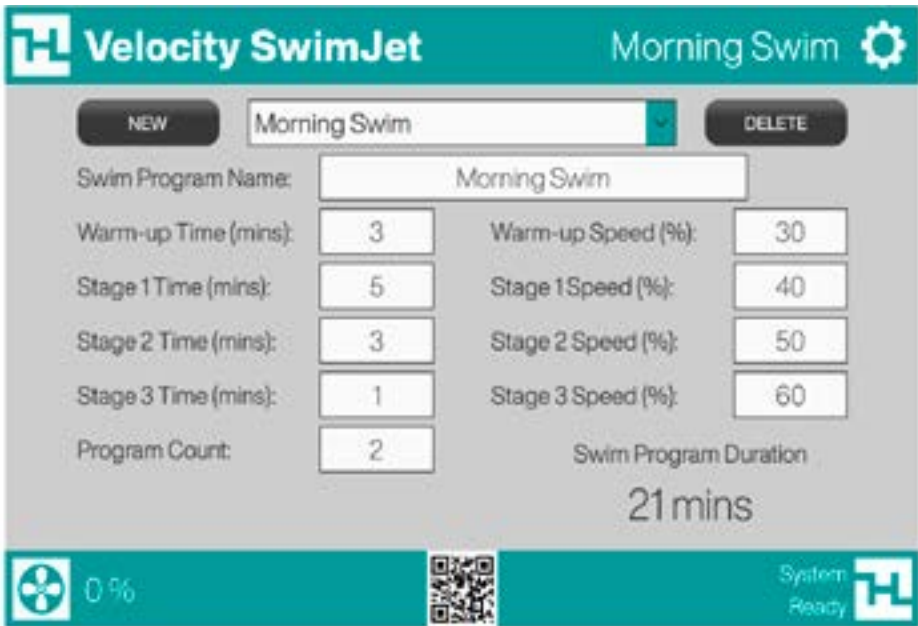

Available as a standalone app for use on a mobile device or tablet at home, or complete with a pre-loaded touch screen, the Velocity SwimApp is ready to suit any user.

VELOCITY	
	Velocity App Control
Velocity App	VEL-APP
Compatible permission code for downloading of the Velocity SwimApp for home device use	£ TBC
	VEL-ALT
Velocity SwimApp pre-loaded onto a 10" splashproof tablet for use in the pool hall	£ TBC

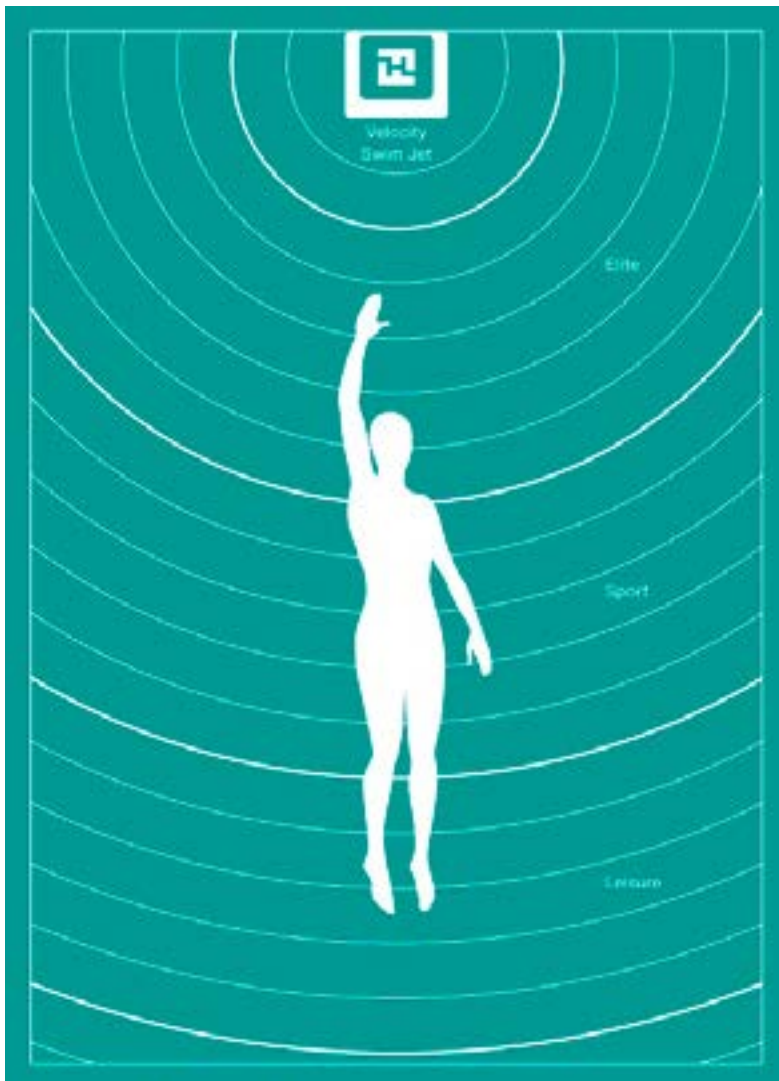



Insulated Panel Pools

by HeatForm

INTRODUCTION	p.158
• In-Ground Pools	p.162
• Customisation	p.164
• Above Ground and School Pools	p.165
• Internal Steps	p.169
• Sports Pools	p.171

Insulated Panel Pool System

Simple and effective in design, the HeatForm insulated panel-pool system offers an affordable and eco-friendly solution to building a dream pool.

Manufactured in Devon using specialist insulation made from 100% recycled plastic PET bottles, this unique system can reduce a pool's energy consumption by 50% compared to a traditional concrete pool.

The fully customisable and straightforward modular system caters for a broad range of settings from the most compact of garden sites to large-scale commercial settings. The system is particularly suitable where access is limited or there is a sloping terrain. A HeatForm pool compromises nothing on quality or luxury by offering you a quality product whose innovative, energy efficient design also helps the environment.



The HeatForm system caught my attention whilst I was planning my garden refurbishment. Its clever use of recycled plastic insulation appealed to me as not only does this increase the energy efficiency of the pool, but it also keeps the running costs low. The pool was installed easily and quickly and the whole family are now enjoying our new and exciting garden feature!"

Helen

HELEN SKELTON, TELEVISION PRESENTER AND ACTRESS

Materials and Construction

HeatForm has transformed the swimming pool construction process. The added value of insulation keeps expensive heating bills to a minimum, whilst also helping to reduce the amount of energy required to keep your pool at a comfortable temperature. Not only does it reduce the amount of energy being wasted through heat loss, but it also helps the environment by using empty plastic (PET) bottles to form the insulated section of the pool wall. Made from 100% post-consumer (recycled) PET material, the foam core meets not only the stringent technical requirements for composites, but also helps to preserve and enhance the human environment.



Every HeatForm panel is made to measure in our specialist fabrication unit in South Devon.

Panel Make-up

An 80mm core of recycled insulation is sandwiched between a toughened fibreglass exterior. Each of the panels bolt together to form a basic pool shell. This flexible system is easy and quick to install and can be adjusted within half metre increments at varying depths. A HeatForm panel pool can be installed indoors or outdoors, above or in-ground.

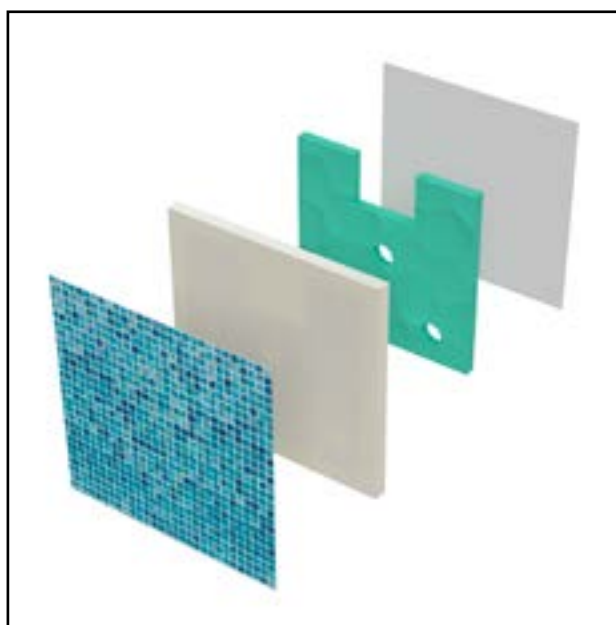

Quick and Easy Installation



The walls for a typical 10m x 5m pool shell can be erected in just a day!

- 1) Site location identified for suitability
- 2) Site excavated
- 3) Floor drains installed
- 4) Concrete slab laid
- 5) HeatForm walls installed
- 6) Pool braced ready for back-fill

Picture courtesy of Gala Pools



In-Ground Panels and Pool Kits

HEATFORM IN-GROUND PANELS - PRODUCT CODE - F

Pool Size (m)	6 x 3	7 x 3.5	8 x 4	9 x 4.5	10 x 5	11 x 5.5	12 x 6
RRP	£ 11,502	£ 13,419	£ 15,336	£ 17,253	£ 19,170	£ 21,087	£ 23,004



Picture courtesy of C'Spas



Picture courtesy of Crystal Leisure



Picture courtesy of C'Spas



Picture courtesy of Neptune Pools

> HEATFORM CUSTOMISATION

HeatForm was designed to offer customers the greatest flexibility possible around the shape of their pool design. Hexagonal, Roman ended* or even rocket shaped pools can be achieved quickly and easily with the modular system!

Our in-house design team are always happy to work with you to achieve the desired pool shape, consulting with the engineers to create a bespoke solution which will stand the test of time.



Picture courtesy of Cornwall Pools



Picture courtesy of Gala Pools



* Third party Roman ends can be integrated into the HeatForm panel pool system and pool sizes adjusted to suit.

Above-Ground and School Pools

Above-Ground HeatForm

Manufactured in Devon, UK with insulation made from 100% recycled PET plastic bottles, HeatForm's above-ground pools are entirely flexible, available in unlimited lengths and widths and with three height options, there is a solution to suit everyone.

Our above-ground pools are quick and easy to install, allowing you to put a pool in a garden, basement or building where an in-ground pool would not always be possible.

A steel support system surrounds the panels creating a strong and sturdy structure, which is bolted to a concrete floor slab. Adjustable elements are built into the design to remove alignment issues and ensure a perfect finish to your pool project.

Each pool can be customised with a pool liner of your choice and you can select from our wide range of pool products (covers, pumps, robotic pool cleaners, heating and water treatment solutions) to complete the ultimate pool package.

Counter current exercise jets can add an extra fitness element to your pool. Our specially developed vanity panel* can be added into the pool build to incorporate the Swimeo or Velocity swim jets.

* Adapted vanity panels can also be made available on request for the majority of other jet brands.

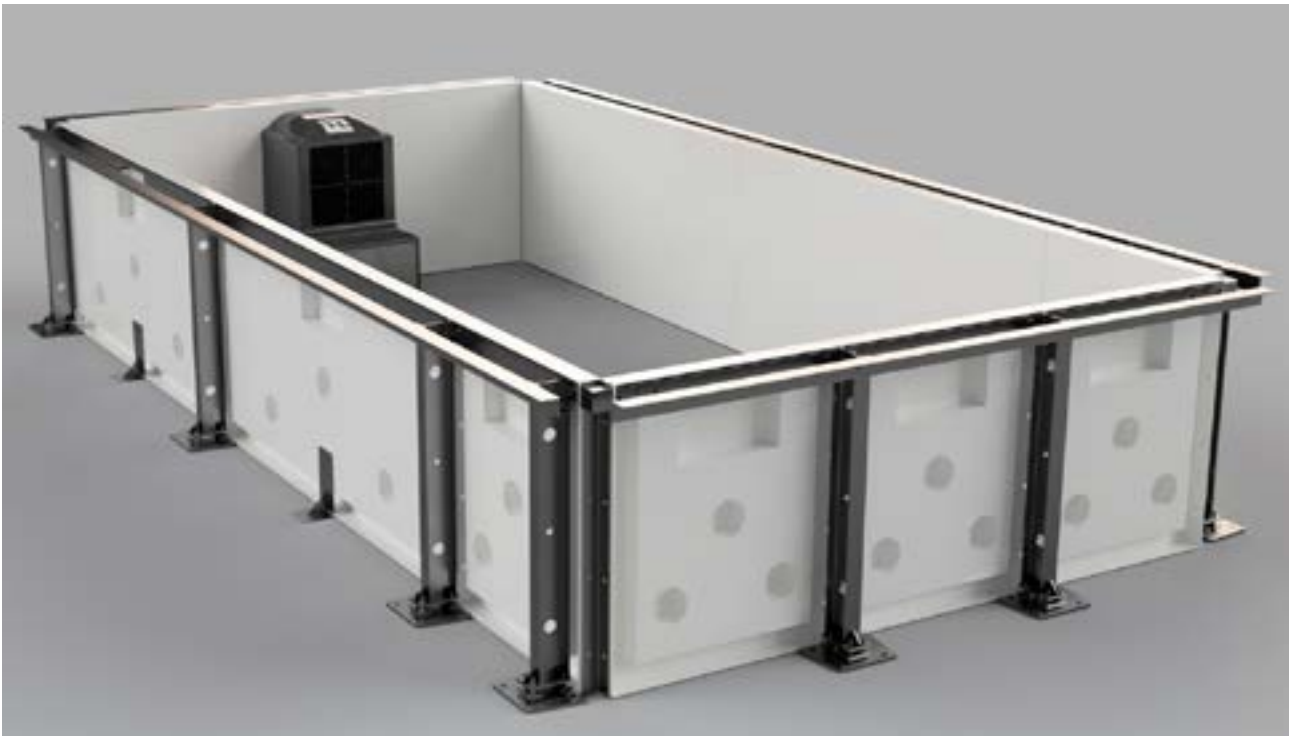

Benefits of a HeatForm above-ground panel pool

- Eco-friendly panel pool system, insulated with 100% recycled PET plastic bottles
- Reduces heating costs by up to 50%
- Modular construction allowing easy access to tight spaces such as basement builds and awkward sloping gardens
- Easily adjusted, galvanised steel support frame
- Smooth clean wall panels giving a professional pool build ready for lining
- Fast and efficient installation
- Pre-positioned recesses for filtration and light fittings
- Manufactured in Devon, UK, reducing your transportation carbon footprint



Picture courtesy of Crystal Leisure



Picture courtesy of C'Spas



Picture courtesy of Aquafun



Picture courtesy of C'Spas



Picture courtesy of C'Spas



Picture courtesy of C'Spas





Picture courtesy of SPS

HEATFORM STEPS

Designed and manufactured in Devon, UK, HeatForm step units have been developed to fit into any liner pool, new or refurbished, quickly and easily.

HeatForm steps are available in a range of styles and varying heights to suit a wall depth of up to 1.5m.

Designed with the end user in mind, all HeatForm step units have a riser height of 240mm, and tread depth of 300mm, providing comfortable and easy access into the pool.

HEAT FORM STEPS - PRODUCT CODE - F		
Straight		
	HFSTEP Straight	HFSTEP Corner
RRP	£ 2,245	£ 3,985

The HeatForm steps are simply installed in the pool shell prior to installing the pool liner. Suitable for installation in conjunction with both on-site lining and pre-tailored lining systems, the HeatForm steps are an easy and quick solution to adding a touch of elegance to any liner pool.

All models are available from stock, in two separate heights (1.2m for 1.5m pool wall depth and 0.9m for 1.2m pool wall depth). Due to the versatile nature of their construction, we can supply them made to measure at any height below 1.2m as part of a custom order.

Please note: If there is any chance of ground water ingress into the pool shell, it is recommended to install a vent kit through the wall. This is to allow any trapped air to be released and avoid any damage to the pool lining. Please see an example illustration of a vent system installation below:

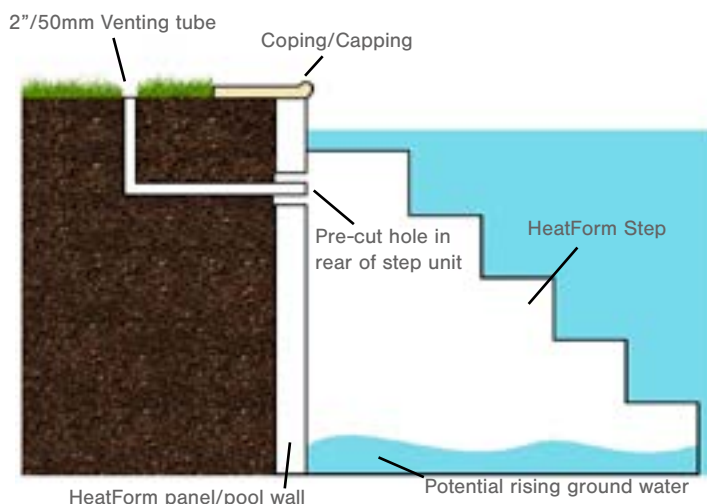

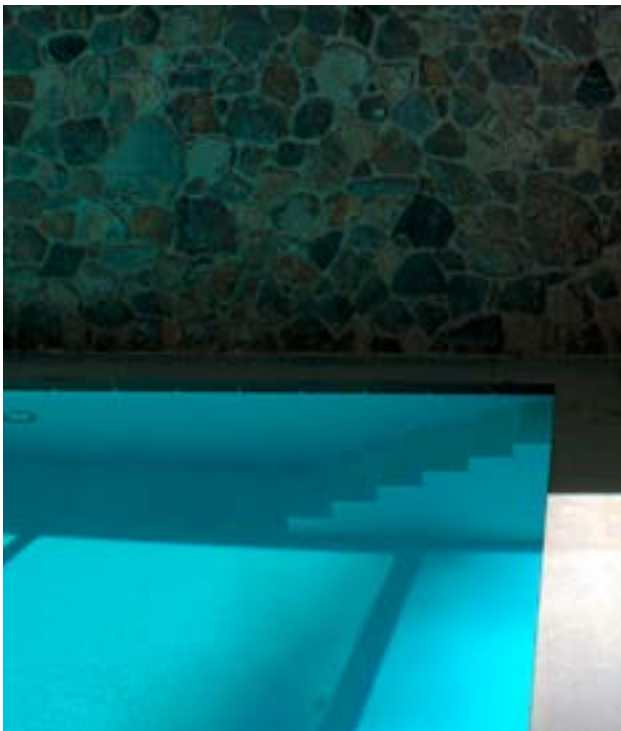
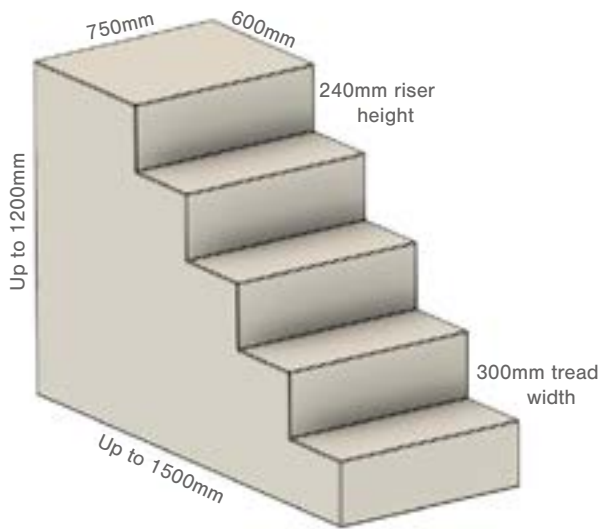

Picture courtesy of Pools And Leisure Services

Our HeatForm panel pools can be purchased in kit form, complete with all the necessary equipment required for installation. The kit includes everything you need to bring the pool from shell to water ready. Supplied with a high quality bag liner from Aquaflex, heating, lighting and filtration equipment from Lighthouse, all pipework to run to a plant room up to 3m from the pool, ladder and a safety cover, the kits are comprehensive, easy to install and time saving.

The kits can be purchased in two sizes, 5m x 2.5m and 6m x 3m and the height requirement can be specified at 1.2m or 1.5m. The kits can be provided in an above ground configuration which have an adjustable steel support system which allows the panels to be fixed to a concrete floor, providing a fully self-supported pool which can be situated either indoors or outdoors, or an in-ground configuration to cover all potential customer requirements.

The HF SPORT variant provides a counter current or swim jet solution for users that require a daily exercise solution.



Picture courtesy of H & H Pools



Picture courtesy of Crystal Leisure



HF SPORT

HF SPORT Pools, supplied with our very own integrated Swimeo swim jet or Velocity counter current, are designed to optimise all levels of workout and physical therapy from triathlon or swim training, through to gentle rehabilitation to help ease aches and pains.

Swimming against a smooth counter-current or swim jet, you effectively swim on the spot and never reach the end of the pool. They are a perfect choice for people who perhaps do not have the space or budget for a full size pool, but want to invest in all the physical and mental benefits that swimming has to offer.

The HF SPORT is available in two sizes – 5m x 2.5m and 6m x 3m, with depth options of 1.5m wall (1.35m water) or 1.2m wall (1.05m water) and can be installed in-ground or above-ground.

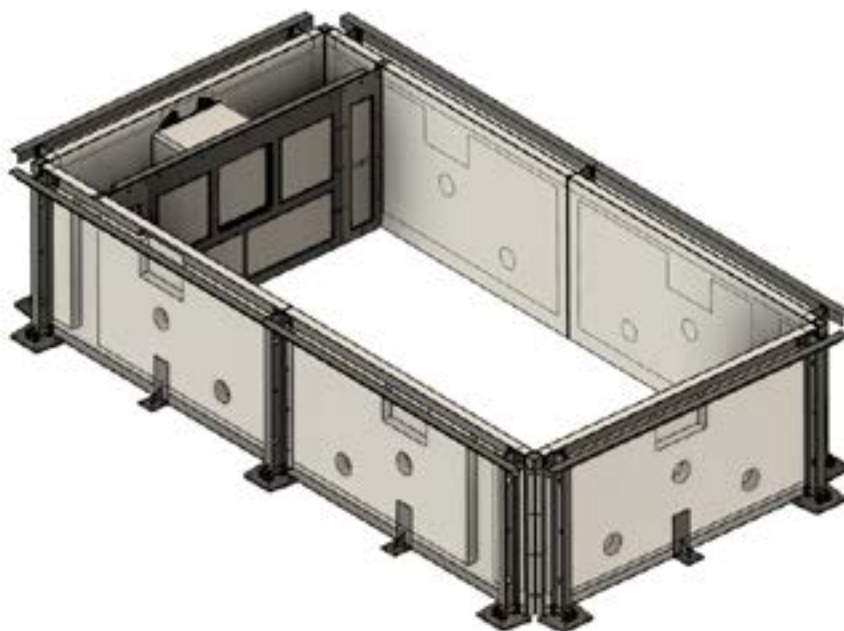

Picture courtesy of C'Spas

HF SPORT IN-GROUND KIT - PRODUCT CODE - F		
	HF SPORT 5000 5m x 2.5m Basin	HF SPORT 6000 6m x 3m Basin
HF SPORT IN-GROUND WITH OVER WALL VELOCITY	HF-IGP-5000-RET	HF-IGP-6000-RET
<p>HF SPORT panel pool with over the wall Velocity counter current including full installation kit.</p> <p>Installation kit includes:</p> <p>HF Alphaflo 50m Pump, Waterco 500 Filter, Bag Liner, Bubble Cover, 1 x 24w RGBW Light and Transformer, Elecro Electric Heater/Heat Exchanger, 1 x Eyeball Inlet, 1 x Low Suction, 3 x Threaded Nipple, 1 x Spa Skimmer, 4 x 3m 1.5" lengths of pipe, 10 x 90° 1.5" Elbows, 2 x 1.5" T Pieces, 3 x 1.5" Ball Valves, 1 x Glue, Liner Lock to suit including screws</p>	£ 26,097	£ 28,571
HF SPORT IN-GROUND WITH HIDDEN VELOCITY	HF-IGP-5000-HID	HF-IGP-6000-HID
<p>HF SPORT panel pool with hidden Velocity counter current or Electric Swimeo Jet with vanity panel, including full installation kit.</p> <p>Installation kit includes:</p> <p>HF Alphaflo 50m Pump, Waterco 500 Filter, Bag Liner, Bubble Cover, 1 x 24w RGBW Light and Transformer, Elecro Electric Heater/Heat Exchanger, 1 x Eyeball Inlet, 1 x Low Suction, 3 x Threaded Nipple, 1 x Spa Skimmer, 4 x 3m 1.5" lengths of pipe, 10 x 90° 1.5" Elbows, 2 x 1.5" T Pieces, 3 x 1.5" Ball Valves, 1 x Glue, Liner Lock to suit including screws</p>	£ 28,079	£ 30,553



Picture courtesy of Gala Pools

HF SPORT FREE STANDING ABOVE GROUND KIT - PRODUCT CODE - F

	HF SPORT 5000 Free Standing 5m x 2.5m Basin	HF SPORT 6000 Free Standing 6m x 3m Basin
HF SPORT ABOVE-GROUND WITH OVER WALL VELOCITY	HF-AGP-5000-RET	HF-AGP-6000-RET
<p>HF SPORT panel pool including HeatForm galvanised adjustable framework system including fixings, with over the wall Velocity counter current including full installation kit.</p> <p>Installation kit includes:</p> <p>HF Alphaflo 50m Pump, Waterco 500 Filter, Bag Liner, Bubble Cover, 1 x 24w RGBW Light and Transformer, Elecro Electric Heater/Heat Exchanger, 1 x Eye-ball Inlet, 1 x Low Suction, 3 x Threaded Nipple, 1 x Spa Skimmer, 4 x 3m 1.5" lengths of pipe, 10 x 90° 1.5" Elbows, 2 x 1.5" T Pieces, 3 x 1.5" Ball Valves, 1 x Glue, Liner Lock to suit including screws.</p>	<p>£ 33,858</p>	<p>£ 37,886</p>
HF SPORT ABOVE-GROUND WITH HIDDEN VELOCITY	HF-AGP-5000-HID	HF-AGP-6000-HID
<p>HF SPORT panel pool including HeatForm galvanised adjustable framework system including fixings, with hidden Velocity counter current or electric Swimeo Jet with vanity panel, including full installation kit.</p> <p>Installation kit includes:</p> <p>HF Alphaflo 50m Pump, Waterco 500 Filter, Bag Liner, Bubble Cover, 1 x 24w RGBW Light and Transformer, Elecro Electric Heater/Heat Exchanger, 1 x Eye-ball Inlet, 1 x Low Suction, 3 x Threaded Nipple, 1 x Spa Skimmer, 4 x 3m 1.5" lengths of pipe, 10 x 90° 1.5" Elbows, 2 x 1.5" T Pieces, 3 x 1.5" Ball Valves, 1 x Glue, Liner Lock to suit including screws.</p>	<p>£ 35,840</p>	<p>£ 39,868</p>



Picture courtesy of C'Spas



Round and Wooden Pools

AQUATECHNICS ROUND POOLS	p.177
• Introduction	p.177
• Round Pools	p.180
INTRODUCTION	p.181
• Pistoche	p.182
• Weva	p.183
• Urban	p.185



For nearly five decades, Aqua Technics Pools has crafted exceptional one-piece composite pools, earning many accolades along the way. Their cutting-edge swimming pools, produced in a state-of-the-art facility near Perth, Western Australia, epitomise technological advancement and superior craftsmanship. Situated in Australia, renowned for its abundant home swimming pools, their products cater to the most discerning global consumers, tailored for durability in the world's harshest climates.

As a family-owned enterprise for over 47 years, their commitment remains unwavering. Their pools, designed for longevity, have reached all corners of the globe. Aqua Technics' primary aim revolves around ensuring families delight in their pool experience, creating enduring memories that span lifetimes.

AQUA TECHNICS POOLS CRAFT THE FINEST ONE-PIECE COMPOSITE POOLS AVAILABLE GLOBALLY. ENGINEERED FOR ENHANCED AESTHETICS AND ENDURING DURABILITY.



AQUA TECHNICS - ADVANTAGES

INCORPORATING GRAPHENE NANO TECHNOLOGY Revolutionising pool construction, Aqua Technics Pools integrate graphene nano technology, setting them apart as the most robust pools ever engineered.

RESISTANT TO FADING Aqua Technics Pools boast patented Pool ColourGuard® surface technology, designed to combat the damaging effects of UV rays and chemicals, ensuring exceptional resistance to fading.

UNWAVERING QUALITY ASSURANCE Certified to AS/NZS 1838:2021, holding license BMP 520101, a globally recognised benchmark. Adherence to this standard is confirmed through rigorous testing by an accredited independent auditor for complete consumer peace of mind. Additionally, Aqua Technics Pools compliance extends to the ISO 9001 Quality System.

UNRIVALED WARRANTIES Aqua Technics Pools commitment goes beyond statutory consumer rights, offering a PoolColourGuard® Limited 10 Year Interior Surface Guarantee and an extensive 20 Year Structural Warranty.

PRECISE ENGINEERING Designs are meticulously crafted, ensuring exacting tolerances, geometrically perfect shapes, and a flawless surface finish, setting a new standard in precision.

UNSURPASSED STRENGTH Featuring full-sized structural ribs, comprehensively supported steps and bench seating, and a broader edge beam, Aqua Technics Pools stand independently strong, eliminating the need for additional structural enhancements.

SUPERIOR MATERIALS AND CRAFTSMANSHIP Employing high-performance, corrosion-resistant, environmentally friendly materials, Aqua Technics Pools exemplify superior strength and rigidity. With an on-site gelcoat manufacturing facility ensuring the finest product through daily material batching, exclusively using specialty materials, never compromising on quality.

AUSTRALIAN CRAFTSMANSHIP Crafted at Aqua Technics Pools' cutting-edge manufacturing facility near Perth, the largest in Australia. Their pools are tailored to endure the world's harshest conditions, including Australia's relentless sun exposure, showcasing their unwavering commitment to superior quality and durability.



AQUA TECHNICS - ADVANTAGES

ADVANCED GRAPHENE NANO-TECH TECHNOLOGY TRANSFORMING ONE-PIECE POOLS

The ground-breaking Graphene Nano-Tech process integrates revolutionary graphene nano technology into every Aqua Technics pool. Pioneered within their own laboratories, the Aqua Technics team invested over three years in intensive research and development, culminating in the incorporation of graphene into the composite layers of their pools. This marks the inception of a groundbreaking patented construction method, heralding the evolution of one-piece composite pool technology.

30% Enhanced Strength

Graphene, renowned for its incredible strength surpassing steel and titanium, elevates Aqua Technics Pools to new levels of durability; giving enhanced structural integrity and resistance to impacts and flexural strain.

30% Reduced Weight

Aqua Technics Pools' innovative technology reduces pool weight while enhancing structural strength and resistance. Greater pool strength without added weight, facilitating easier transportation and crane handling.

Heightened Resilience

A Graphene Nano-Tech pool boasts superior resistance to water, moisture transpiration, and chemical aggressions. Improved laminate durability and fortified corrosion resistance for prolonged pool life.

Pool ColourGuard®: Unmatched Dual Surface Shielding

Exclusive to Aqua Technics Pools, the patented surface protection system is an unparalleled safeguard embedded in their pools; shielding them from the detrimental impact of ultraviolet rays and chemical attack. Comparable to sunscreen for your pool, it fortifies against colour depletion and weather-induced damage. Through a specialised dual gelcoat integration within the manufacturing process, two layers unite to provide exceptional surface defence. Maintaining a stunning high gloss finish, your pool retains its exquisite appearance, all credit to Aqua Technics Pools' innovative and distinctive Pool ColourGuard® technology. Nothing else on the market comes close to its capabilities.

The Most Celebrated Pool Manufacturer in Australia

Aqua Technics Pools stands as the foremost awarded swimming pool company in Australia, boasting an extensive collection of accolades from local, national, and international bodies and organisations. With over 23 international distinctions, including esteemed SPATA Awards in the UK and a prestigious European EUSA Award, Aqua Technics Pools' global recognition attests to the exceptional quality of their pools. Consistently recognised for excellence, Aqua Technics Pools proudly clinched the Fibreglass Pool Builder of the Year award at the SPASA Awards of Excellence in 2019, 2020, 2021, and 2022.

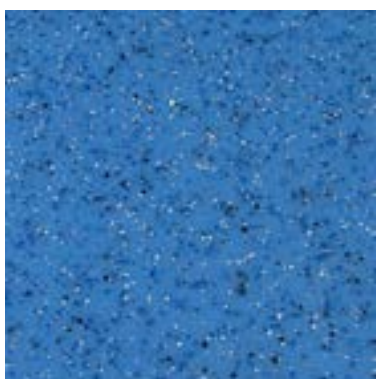

Horizon Blue

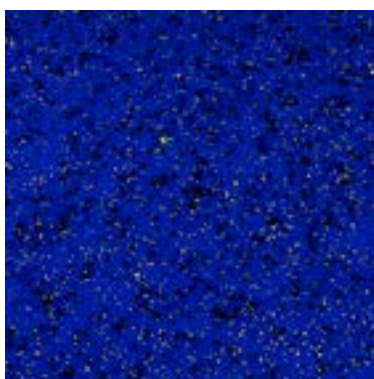

Twilight Blue

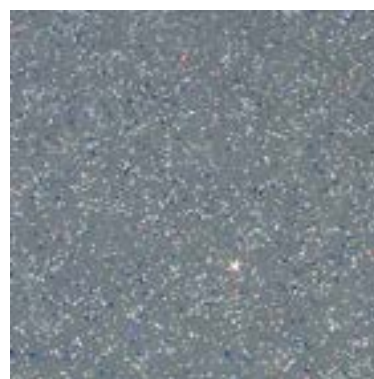

Platinum Grey

AQUA TECHNICS ROUND POOLS - PRODUCT CODE - G

	Aqua Technics 3m Round	Aqua Technics 4m Round		
Aqua Technics Round Pool Standard Equipment	AT-3m-Round-ST	AT-4m-Round ST		
1 x Round pool shell 1 x 4m ³ /hr surface water skimmer 1 x return inlet 2 x low level suction 1 x white LED light Pre plumbed with 63mm PVC pipe	£ 19,448	£ 26,600		
Aqua Technics Round Pool Special Equipment	AT-3m-Round-SP	AT-4m-Round-SP		
1 x Round pool shell 1 x 4m ³ /hr surface water skimmer 1 x return inlet 2 x low level suction 1 x white LED light Pre plumbed with 63mm PVC pipe 4 x rotary massage jets 2 x low level booster suction Pneumatic switch at spa-side for massage jets and light	£ 21,050	£ 28,657		
Aqua Technics Round Pool Executive Equipment	AT-3m-Round-EX	AT-4m-Round-EX		
1 x Round pool shell 1 x 4m ³ /hr surface water skimmer 1 x return inlet 2 x low level suction 1 x white LED light Pre plumbed with 63mm PVC pipe 6 x rotary massage jets 2 x low level booster suction Seat air pots x 14 Pneumatic switch at spa-side for massage jets and light	£ 23,108	£ 34,834		
	Alphaflo 0.5hp Pump	Turboflo 200 Booster Pump	Waterco Cartridge Filter	Waterco Airblower - 900w

PRODUCT CODE - C

Standard model	27122210	27136210	27138210	27194210
	£ 770	£ 850	£ 364	£ 482



TECHNICAL DETAILS

Model	3.0 Round Pool	4.0 Round Pool
Pool shapes	Round	Round
Internal Size	3.0m	4.0m
Pool Depth	1.45m	1.45m
External Size	3.4m	4.4m

ASSOCIATED PRODUCTS



Ottimo heat pump

See Page - 24



Just Salt

See Page - 103



HeatForm Alphaflo Pumps

See Page - 52

THE LITTLE POOL Pistoche



PROTECTION

SELF-RETRACTING PROTECTIVE COVER.*

Pistoche pools are equipped with a protective cover to close the pool and prevent access while the pool is not in use. In addition, because you can never be too careful, this cover can withstand the weight** of little explorers who happen to climb on top of it.

In addition to securing the pool, the cover protects the pool against evaporation and night time cooling. It also prevents pollen, dust and leaves from falling into the pool. The water stays clean, always ready for your little swimmers. A Pistoche exclusive!

1



The cover is built into a cover pit that is hidden under the edging.

2



Once the edging on all 4 sides has been lifted, the cover can be rolled out in just a few seconds by pulling on the strap, a sharp tug will cause the cover to automatically roll up.

3



Strong and hard wearing and fitted with a purpose designed fastening system, the cover can bear the weight of a small child.

* This cover is no substitute for common sense or individual responsibility. Nor is it intended to replace the vigilance of parents and/or responsible adults which remains the key factor in ensuring the safety of young children.

** 20 Kg max



SOLID

MADE IN FRANCE - 2 YEAR GUARANTEE.

Pistoche pools are made in Brittany in Northern France. Hard wearing materials and manufacturing quality are fully guaranteed.



WOOD

BASE STRUCTURE MADE OF REAL, SOLID PEFC WOOD, CLASS IV AUTOCLAVE TREATED (CTB-B+ SP).

TOP STRUCTURE MADE OF CLASS III NORTHERN PINE. GUARANTEED 2 YEARS.

Sturdy and aesthetic, Pistoche has a place in every garden.



2 X 2 METERS

THE IDEAL SIZE FOR LITTLE SWIMMERS.

Water that is always clean and temperate. A pool that can be placed anywhere, even in a tiny garden, thanks to its space saving dimensions (interieur dimensions: 2 x 2 x 0.64 m - overall dimensions: 2.26 x 2.26 x 0.68 m).



EASY TO ASSEMBLE

BUILT IN 6 HOURS.

Putting a Pistoche pool together is child's play! In six hours, with just two people on the job, the pool is built and ready for use. A precise assembly diagram and detailed instruction booklet are included with Pistoche.



EVOLUTIVE

ADJUSTABLE FILTRATION HEIGHT, FOR A WATER LEVEL BETWEEN 40 AND 60 CM.

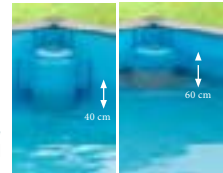

The cartridge filter, that ensures the quality of water in the pool, may be installed in any of the four corners so that it faces into the prevailing wind. The depth of the water may be adjusted depending on the height and age of the children: forty centimeters for the youngest children to splash around, and up to sixty centimeters for older children to start swimming. A Pistoche exclusive!

A Pistoche exclusive just for us!

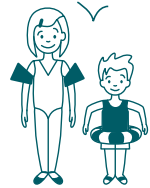

2 PACKAGES

THE PISTOCHE POOL COMES IN TWO PACKAGES.

Package 1/2 contains: the height adjustable filtration system, dark blue, 0.50 mm liner, the underlay and the nuts, bolts and screws.

The wooden structure is enclosed in the second package, this package contains all the wooden elements, the PVC profiles, the aluminium coping, the roller already fitted with the protective cover and its strap.

Pistoche.fr by PROCOPI

PRODUCT CODE: 27160209



STYLISH FINISH!
Pistoche pools are now equipped with Aluminium coping



16002 - Non-contractual document. Data is provided for information purposes only and may be subject to modification without prior notification. Copyright protected. Please do not litter. Created by: BWT POOL PRODUCTS (04/2023a)

> PISTOCHE

THE LITTLE POOL

- + Built in Safety Cover
- + Easy to assemble
- + One size - 2m x 2m
- + Complete pool



PRODUCT CODE - G

Product reference: 27160209

£ 2,124

PISTOCHE

Type of pools	Wooden pool with safety cover included
Pool size	2m x 2m x 0.64m
Lining	Blue liner



WEVA WOODEN POOLS

Above-ground / partially in-ground / in-ground

Pool structure made of class IV treated solid Northern pine, P-FI filtration group that is easy to install, removable access ladder, double width coping made of Class IV treated pine, dark blue 0.75 mm liner.



NEW NORTHERN SPRUCE COPING

For more beautiful, flatter coping with a longer service life, BWT chose class III treated Northern Spruce, selected based on its resilience, mechanical strength and excellent weatherability. Beautiful wood, properly cured, dense, top quality, for pools that will delight your customers for years to come.

COPING



- » Class III treated Northern spruce, 28mm thick and 290 mm wide (2 x 145 mm).

LINER



- » Liner 0.75 mm, dark blue.

LADDER



- » Stainless steel in-pool ladder, 3 steps
- » Wooden access ladder, 5 treads



RETURN FITTINGS AND SKIMMERS

- » 1 return fitting,
- » 1 skimmer P-PM Corps.



FILTRATION GROUP

- » Flow rate 8.30 m³/h at the return fitting outlet (clean filter)
- » Sand filter, Ø 500 P-FI, UV stable
- » 6-way valve (filtration/ back-wash/ rinse/ circulation/ drain/closed).
- » Isolating valves on the return and suction lines
- » Filtration pump fitted with a prefilter; power 0.46 to 0.60kW
- » Semi-rigid, buriable hydraulic fittings, Ø 45mm.

Every BWT myPOOL pool and mini-pool complies with French and European standards in effect:

- NF EN 16582-1 | Private family pools/ part 1: general safety requirements and test methods.
- NF EN 16582-2 | Private family pools/ part 2: general safety requirements and test methods for in-ground pools.
- NF EN 16582-3 | Private family pools/ part 3: general requirements concerning security and test methods for above-ground pools.
- NF EN 16713-1 | Private family pools/ Water distribution systems – Part 1: Filtration systems/ Requirements and test methods.
- NF EN 16713-2 | Private family pools/ Water distribution systems – Part 2: Circulation systems/ Requirements and test methods.
- NF EN P90-303 | Paddling pools – Safety requirements and test methods.



INTERLOCKING STRUCTURE

- » Class IV treated solid Northern pine, rounded finish
- » Thickness, 45 mm.
- » Galvanised steel supporting braces.



UNDERLAY

- » Underlay to be fitted under the liner.

> WEVA WOODEN POOLS

THE HASSLE FREE, PRACTICAL RANGE

- + Above and in-ground
- + Easy to assemble
- + Five sizes
- + Complete pool kit



	Octo 530	Octo+ 640	Octo+ 840	Rectangle 6 x 3	Rectangle 8 x 4
PRODUCT CODE - G					
Standard model	27122210	27136210	27138210	27194210	27196210
	£ 6,793	£ 9,503	£ 11,796	£ 11,255	£ 14,489

THE RANGE					
Shape	Octogan	Octogan	Octogan	Rectangle	Rectangle
Size (External)	530 cm	644 x 404 cm	843 x 489 cm	853 x 453 cm	800 x 400 cm
Size (Internal)	470 cm	590 x 350 cm	789 x 435 cm	653 x 353 cm	600 x 300 cm
Height inc coping	133 cm	146 cm	146 cm	146 cm	146 cm
Water Vaolume	18.77 m3	18.51 m3	41.25 m3	24 m3	42.56 m3

EQUIPMENT INCLUDED					
Metal Structure	No	Yes	Yes	Yes	Yes
Liner Thickness	0.75mm				
Liner Colour	Dark Blue				
Filtration Kit	Yes				
Stainless Ladder	Yes				
External Wooden Ladder	Yes				

ASSOCIATED PRODUCTS



Neo Inverter heat pump

See Page - 18



Just Salt

See Page - 103



Velocity Counter Current

See Page - 151

> URBAN WOODEN POOLS - WITH SLATTED COVERS



> URBAN WOODEN POOLS - WITH SLATTED COVERS

THE HASSLE FREE, PRACTICAL RANGE

- + Built-in Slatted Covers
- + Above and in-ground
- + Easy to assemble
- + 3 different sizes
- + Complete pool kit



	Urban 420	Urban 600	Urban 650
PRODUCT CODE - G			
Standard model	27181614	27180614	27184218
	£ 12,878	£ 12,878	£ 15,842

THE RANGE			
Shape	Rectangle	Rectangle	Rectangle
Size (External)	419 x 353 cm	603 x 253 cm	653 x 398 cm
Size (Internal)	314 x 300 cm	500 x 200 cm	550 x 300 cm
Height inc coping	133 cm	133 cm	133 cm
Water Volume	13.30 m3	13.40 m3	21.90 m3

EQUIPMENT INCLUDED	
Metal Structure	Yes
Liner Thickness	0.75mm
Liner Colour	Light Grey
Filtration Kit	Yes
Stainless Ladder	Yes
External Wooden Ladder	Yes
Automatic Slatted Cover	Yes - Light Grey

ASSOCIATED PRODUCTS



Neo Inverter heat pump

See Page - 18



Just Salt

See Page - 103



Velocity Counter Current

See Page - 151



GENERAL TERMS OF SALE LIGHTHOUSE POOLS

Contract

The contract for sale is made when we confirm receipt of your order by e-mail. The contract is governed by English law.

1. Terms and Conditions of Business

1.1 Are reproduced below, and shall apply to all products and services supplied by Lighthouse Pools, whether priced in the current price list or otherwise.

2. Definitions

Except where the context otherwise requires, the following expressions shall have the meaning shown against them:

"Company" Lighthouse Pools Limited.

"Conditions" these Terms and Conditions of Business.

"Contract" an agreement between the Company and the Customer for the supply of Goods or Services.

"Customer" the purchaser of the Goods or Services.

"Deliver" includes "procure to be delivered" and "delivery" shall be construed accordingly.

"Goods" any Goods, equipment or other thing supplied (including where appropriate any part or component thereof) by the Company to the Customer.

"Services" any service provided by the Company at the Customer's request.

"Prices" all prices are suggested retail and are quoted ex-works, and will be subject to delivery and VAT.

"Writing" includes any communication effected by letter, telex, cable, facsimile, electronic mail or other comparable means of communication.

3. Application

3.1 Any supply of Goods or Service by the Company shall be subject to these Conditions.

3.2 No term or condition of the Customer's standard terms of trading contained or referred to in the Customer's order, acceptance or otherwise shall form part of any Contract and no such term or condition shall modify or amend these Conditions or any Contract.

3.3 No change to any Contract or any change to or waiver of these Conditions shall have any legal effect, unless agreed to in writing by a Director of the Company, provided the Company may amend these Conditions by notice in writing with regard to Contracts entered into after such notice.

3.4 The headings in these Conditions are for convenience only and shall not affect its interpretation.

4. Orders, Quotations and Cancellation of Contract

4.1 The Customer's order for Goods shall be made or confirmed by the Customer in writing but a Contract shall not be made until an order is accepted by the Company. The Company may communicate its acceptance to the Customer either in writing or by despatching (or procuring the despatch of) the Goods.

4.2 (a) Any offer by the Company to sell Goods to the Customer shall be made in a written quotation. Any quotation made by the Company is given on condition a Contract shall not be formed until the Company has received the Customer's written acceptance thereof.

(b) The Company may amend or withdraw a quotation at any time before it has received the Customer's written acceptance.

4.3 The Customer may not return any Goods supplied in accordance with the Contract after the Contract has been made. The Company may, at its absolute discretion and following the Customer's prior written request, agree to the cancellation of an order and/or to the return of any Goods and it shall be a condition of the Company exercising its discretion which:

(a) The Goods to be returned form part of the Company's normal stock holding.

(b) The Customer shall pay the Company a sum equal to the greater of 20% of the price of the Goods or £20 for each item comprising the Goods;

(c) Any Goods returned are in their original condition;

(d) The Customer shall, in addition, be liable for the costs of delivery or re-delivery.

5. Prices

5.1 Unless otherwise agreed in writing, all prices are ex-warehouse and exclude the cost of delivery.

5.2 Except where any quotation by the Company provides the price for Goods shall be fixed for a given period, the price for Goods shall be prevailing when they are despatched.

5.3 The Company reserves the right to make additional charges when there is any delay in being supplied with delivery instructions or if prior to delivery the Company incurs any additional costs.

5.4 Unless otherwise stated in writing the price for Goods is exclusive of VAT and all other taxes, fees, dues, duties or other assessments or charges.

6. Delivery and Risk

6.1 Unless otherwise agreed, delivery of the Goods shall be at the Customer's premises.

6.2 Time of delivery shall not be of the essence of any Contract. The Customer shall allow a reasonable time for the Company to deliver Goods and the Company will use its reasonable endeavours to meet any stated delivery dates but accepts no liability whatsoever for any failure to do so.

6.3 If the Customer fails to take delivery of any Goods in accordance with a Contract then the Company, at its option shall:

(a) Arrange for storage at the Customer's risk and cost (including the costs of transportation).

(b) At anytime after the due date for delivery, terminate the Contract in accordance with clause 13.1.

6.4 Where delivery is made by instalments if the Company fails to make delivery or makes defective delivery of any instalment, then such failure or defective delivery shall not affect the obligations of the Company and of the Customer as to the remaining instalments.

6.5 Except where risk in Goods would pass earlier in accordance with clause 6.3 or 6.6, risk in the Goods shall pass from the Company to the Customer upon delivery.

6.6 Where the Company is unable to deliver Goods in accordance with the Contract for any reason other than the Company's default, the Company may either in its own name or as agent for the Customer, arrange for storage of the Goods. The Company shall be considered to have fulfilled the Contract immediately upon delivery being made to the place of storage and risk and all charges for storage and ultimate delivery shall be borne by the Customer.

7. Claims

7.1 The Customer shall inspect the Goods immediately upon delivery.

7.2 (a) The Customer shall give written notice to the Company and any carrier within 24 hours of delivery, of any failure of the Goods to comply with the Contract.

(b) Where the Customer has not received any Goods despatched by the Company, it shall give written notice to the Company within 14 days of having been notified of despatch.

7.3 Provided the Customer complies with clause 7.2, the Company will replace all Goods which have not been delivered and, at its option, repair or replace Goods which are not in conformance with the Contract.

8. Retention of Title

8.1 Notwithstanding delivery and the passing of risk, the Company shall remain the sole legal and beneficial owner of goods which it supplies to the Customer pursuant to any contract until:

(a) The Customer has paid for those goods in full, and also

(b) The Customer has paid in full for all other goods supplied to the Customer by the Company, but not yet paid for in accordance with the Company payment terms.

8.2 Notwithstanding any purported appropriation to the contrary, the Company shall be entitled to appropriate any payment or payments for goods made by the Customer to the Company to such goods and accounts as it shall deem fit.

8.3 The Customer shall insure all the Company's goods to their full value against all risks and shall procure that a note of the Company's interest therein is endorsed on the certificate of insurance. The Customer shall indemnify the Company in respect of the loss or destruction of the Company's goods or damage to them, and shall hold any insurance monies paid in respect of them in trust for the Company and account for such monies forthwith to the Company.

8.4 The Customer shall hold all the Company's goods in a fiduciary capacity on behalf of the Company, shall keep them separate from goods which are its own property or the property of any third party; and shall store and label them in a manner which enables them readily to be identified as the property of the Company.

8.5 In the event that the Customer is supplied goods by a third party which are identical to Goods supplied hereunder then the Customer shall be obliged to sell the goods supplied by such third parties before selling any identical goods supplied hereunder.

8.6 In order to identify and recover goods the Company or its representative are entitled to assume unless the contrary is shown to their satisfaction that the Customer has acted in accordance with the provisions of clause 8.5.

8.7 The Customer shall return all the Company's goods to the Company immediately on the Company's request. The Customer's rights of possession over the Company's goods may be revoked at any time by notice from the Company, and shall cease automatically and forthwith on the occurrence of any circumstance which would entitle an administrator or administrative receiver to take possession of any of the Customer's assets or would entitle any person to present a petition which may be incurred by the Company by reason of any wrongful act of the customer.

Customer in or in connection with any such sale.

8.8 The Customer shall upon notice in writing from the Company, fully and effectively assign to the Company all rights which it may have against any customer or customers of the Customer in relation to a sale or sales of the Company's goods. Such an assignment shall be deemed to take place automatically and forthwith on the occurrence of any circumstance which would entitle an administrator or administrative receiver to take possession of any of the Customer's assets or entitle any person to present a petition for winding-up or the bankruptcy of the Customer.

9. Guarantee and Limitation of Liability

9.1 Principle

Unless otherwise stipulated, we contractually guarantee the correct operation of our new Products. We guarantee that our Products conform to their technical specifications and that they are free of material and manufacturing default.

9.2 The present warranty is limited, at our discretion, either to the repair or exchange for a new or repacked Product, or to the refund of any Products recognized as being defective by our services. Shipping expenses for the repaired or replaced Products delivered to the client will be borne by us, excluding any labour costs, travel and/or accommodation expenses incurred as the result of repairs made outside of continental France and excluding any payment of damages.

9.3 All Product returns must first be approved and decided by our services. Returns sent by the Client without our prior approval will not be accepted.

In particular, the spare parts warranty will only be honoured after analysis and expertise of the returned spare parts by our company followed by the decision to replace said parts. In all cases the seller's legal warranty will continue to apply.

9.4 In order to benefit from the warranty, the Client and the End User agree to respect the following parameters concerning the balance of the swimming pool water:

- pH: 6.8 < pH < 7.6

- free chlorine (*): < 3,0 mg/L

- total bromine (*): < 5,0 mg/L

- stabilising agent (if used): < 75 mg/L

- total dissolved metals (iron, manganese, copper, zinc...): < 0.1 mg/L

(*): Cleaning robots must absolutely be removed from the pool before using a shock treatment.

Note: Using water drawn from a well is forbidden.

9.5 General limitations

The present warranty does not apply to visible defects that the Client failed to report upon accepting delivery of the Products.

Also excluded from the warranty are: defects or deterioration due to the unsuitability of the Product with respect to the end User's needs, due to normal wear, to negligence, to incorrect installation or to a use that does not conform to the recommendations mentioned in the User Manual, to lack of maintenance and/or a handling accident, to incorrect storage, and/or by studies, instructions and/or specifications made by our Client.

Any modifications made by the Client, by the End User or by any third party to our Products will automatically void the warranty in full. The same will apply if original parts were to be replaced with spare parts not sold by us.

9.6 Our Client will be responsible for ensuring compatibility of our Products with any other pool equipment it may be installed with, by checking with the different manufacturers concerned, also for ensuring that all installation and operating instructions and rules are respected in order for the overall system to operate correctly.

9.7 In the case of a return of the product to our workshop, shipping expenses to and from, will be borne by the end user, except for those expenses mentioned under paragraph 2 of the present article.

Immobilisation and deprivation of use of an appliance due to repair will not give the right to compensation.

This warranty will become void in the case of a default in payment or late payment by our Client for the Product concerned.

9.8 Period covered by the warranty

The effective warranty start date is the date mentioned on the sales invoice for the new Product as issued by our Client to the End User. This document will be required as proof of purchase in order for the warranty to come into play. Failing this, our Client shall bear the full cost of any claims made by the end User under the contractual warranty and after its expiry date.

Under no circumstances shall any repairs or replacements carried out under the terms of this warranty cause its duration to be extended or renewed.

9.9 Particular dispositions for Products of Heating and Dehumidification range

Unless otherwise specified, we guarantee the correct operation of our new products installed and put into service by a professional installer (excluding installation via «retrofit» kit») for a period of two years starting from the date mentioned on the invoice as issued by our Client to the end User. Users are also required to have an approved technician perform a regular maintenance according to the instructions detailed in the product user guide.

The warranty only covers defaults in materials and craftsmanship that have been acknowledged by our technical department/services.

The present warranty does not apply to malfunctions and/or degradations due to external factors unrelated to us (bad power supply, adjustment of the bypass, incorrect air circulation, bad insulation of the premises, thermal bridges, incorrect overwintering, etc...).

The heat exchanger of the heat pumps benefits from a 5-year warranty against corrosion.

9.10 Particular dispositions for Products of the Electrical Robots Range

We guarantee that all our products conform to their technical specifications, that they are free from material or manufacturing defects and that they correspond to the technical evolution and state of the art at the time of their launch on to the market.

Subsequent modifications made to our Products (improvements or modifications made as part of the technical development of the products) will not give any right to an intervention on our behalf.

The following are excluded from the warranty:

- Normal wear on parts such as tyres, tracks, belts, brushes, gears and the filter.
- Damage caused by lightning or by an incorrect electrical connection.
- Damage due to shocks, incorrect use or incorrect maintenance (including the robot, its accessories and cables).

The warranty will cover a period of 2 years for all products of the range, from the date of the sales invoice for the new product issued to the end user by our client.

10. Accounts

10.1 Account terms are available subject to status.

10.2 Re-presentation of cheques will be charged at £20 per presentation.

10.3 Purchases using a Credit Card will attract a 3% surcharge.

11. Account Payment

11.1 Unless otherwise agreed in writing by the Company, all invoices shall be paid in full thirty (30) day following the date of invoice. All sums not paid by the due date will become liable for interest charged at 8% above the Bank of England base rate until paid in full.

11.2 Timely payment shall be of the essence of the Contract and in the event of any failure or delay by the Customer to pay for Goods, the Company shall have the rights set out in clause 13.

11.3 Payment for Goods is immediately due and payable upon commencement of any event referred to in clause 13.

11.4 The Company shall have a right of set off and the Customer hereby authorises the Company to apply any money owed by it to the Customer against any monies which may be due from the Customer to the Company.

12. Force Majeure

Except with respect to the payment of money, neither party shall be liable for failure to perform its obligations under these Conditions if such failure results from circumstances beyond such parties reasonable control.

13. Termination

13.1 If any payment or instalment falls due and is not paid in full within 7 days, the Company may without prejudice to any other rights, suspend performance of any of its obligations under these Conditions or terminate the Contract and/or any other Contract for sale of Goods by notice in writing with immediate effect.

13.2 If the Customer becomes insolvent or enters into liquidation, whether compulsory or voluntary (other than for the purposes of amalgamation or reconstruction) or compounds with its creditors generally or has a receiver, administrator, administrative receiver or liquidator appointed over all or any of its assets, or suffers execution or distress or takes or suffers any similar action in consequence of debt or becomes unable to pay its debts as they fall due or fails to perform any obligation required to be performed by it hereunder for a period of 30 days after receipt of notice from the Company of such failure the Company may, without prejudice to any of its rights, terminate the Contract forthwith by notice to the Customer.

14. Assignment

No Contract shall be assigned or transferred in whole or in part by the Customer directly or indirectly without prior written consent of the Company.

15. Trademarks and Trade Names

15.1 Nothing in these Conditions shall be deemed to confer any right upon the Customer to apply any trademark, trade names, colour schemes or design rights owned by the Company or the Company's manufacturers or suppliers.

15.2 The only trademarks or trade names which may be displayed in advertising Goods supplied hereunder shall be those expressly authorised by the Company or its manufacturers or suppliers and the Customer shall comply with the Company's express instructions relating to the context, scale and manner of use of such trademarks or trade names in all such advertising.

15.3 The trademarks, trade names, colour schemes or design rights of the Company or its manufacturers or suppliers shall not, without the Company's prior written consent be used on or in relation to any Goods supplied hereunder which the Customer in any way adds to repacks or otherwise alters and the Customer shall remove or permanently obliterate any such trademarks, trade names, colour schemes or designs of the Company or its manufacturers or suppliers from any Goods so added to, repacked or otherwise altered.

16. Severability

If any part of these Conditions or any other term or condition of this Contract is judged by any competent court to be invalid or unenforceable, the remaining part or parts shall continue in full force and effect.

17. Forbearance

Any neglect, forbearance or indulgence on the part of the Company, relating to rights under these Conditions shall in no way be deemed a waiver, implied or otherwise, of such rights.

18. Notices

Notice will be in writing and will, for all purposes, be deemed to have been fully given and received when actually received and will be sent by registered or recorded delivery mail, postage prepaid (unless otherwise provided), properly addressed to the parties at their registered office or at such other address for either party as may be specified by such party for such purpose, or by telex with receipt acknowledged by answer back.

LIGHTHOUSE

THE SPECIALIST POOL DISTRIBUTOR

7 Meadow Close
Langage Business Park
Plymouth

PL7 5EX

Tel: 01752 253525

sales@lighthousepools.co.uk

www.lighthousepools.co.uk

